

MVP-50P
Twin Engine Installation Instructions

0205091 Rev. C

A8.0 Appendix

Blank Page

Contents

1.0 System Installation Overview	5
2.0 Hardware Installation	11
3.0 Install the EDC Wire Harnesses and Route Wires	35
4.0 Install the MVP Wire Harnesses and Route Wires	43
5.0 Mandatory System Setup and Checkout	47

Blank Page

System Installation Overview

1.1 Installation Overview:	-----	7
1.2 Password Protection:	-----	8
1.2.1 Level #1 Password (Maintenance):	-----	8
1.2.2 Level #2 Password (OEM/Experimental):	-----	9

Blank Page

1.1 Installation Overview:

The installer should start the installation by reviewing the EDC Wiring Work Sheets. There are two sets of worksheets, one set for each EDC. Each set will have three sheets, one for each of the 37-pin D-Sub connectors on the EDC (Top, Middle and Bottom). The work sheets are packaged with each of the two EDC wire harnesses.

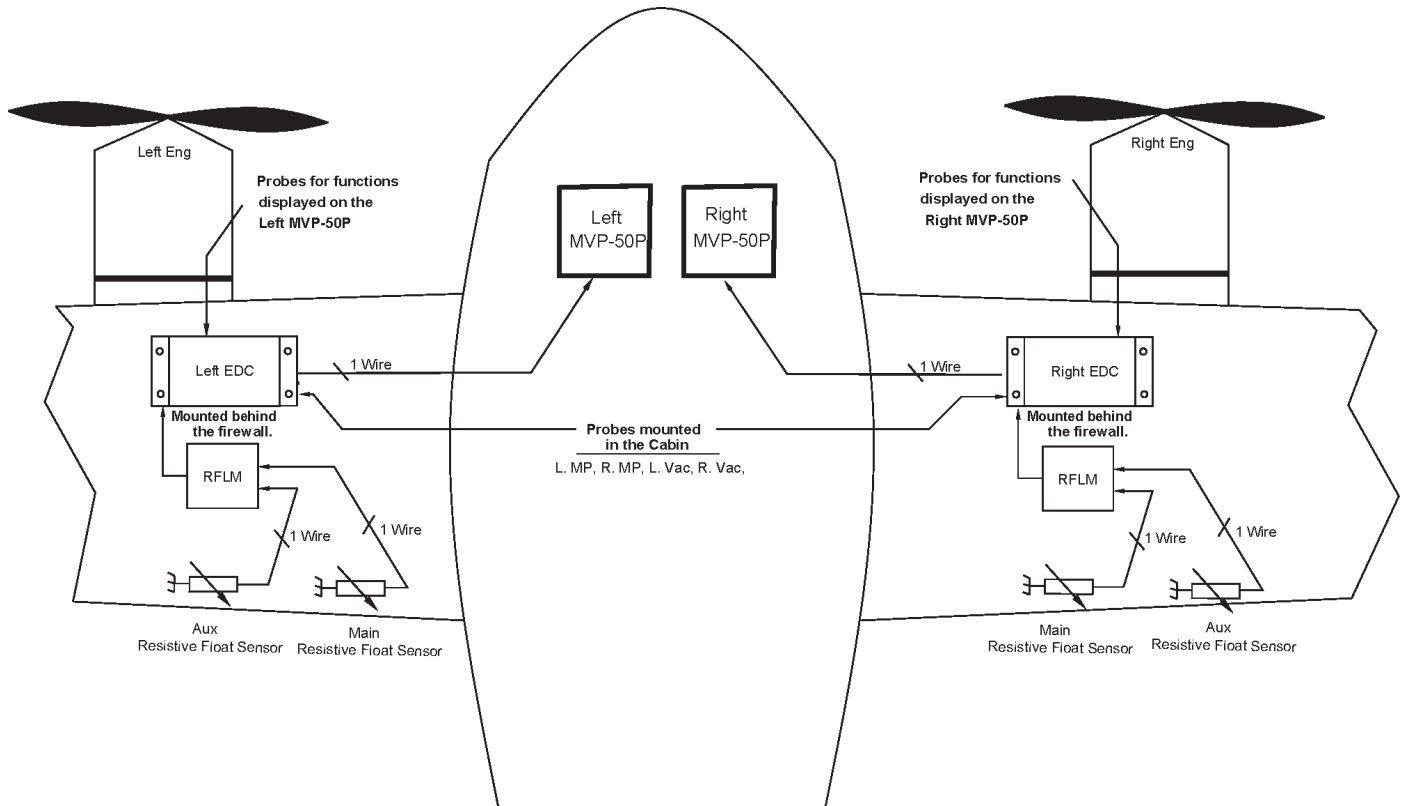

The work sheets provide a list of the probes and transducers included in the kit. Also, it provides the hookup data. The installation is achieved by performing the following steps:

- A. The probes and transducers provided in the kit will be installed on the Left and Right engine.
- B. The Left EDC will be installed on the back side of the left engine's firewall or in the left wing or at the left wing root. The Left EDC monitors the left engine's probes and transducers (EGTs, CHTs, Oil Pressure, Oil Temperature, Fuel Pressure, Fuel Flow, etc.).
- C. The Right EDC will be installed on the back side of the right engine's firewall or in the right wing or at the right wing root. The Right EDC monitors the right engine's probes and transducers (EGTs, CHTs, Oil Pressure, Oil Temperature, Fuel Pressure, Fuel Flow, etc.).

Note: The EDCs should NOT be installed in the engine compartment.

D. The wire harnesses from the EDCs to the probes and transducers will be installed. Refer to the EDC work sheets for hookup information. There are two wires (RS422) from each EDC that must route into the cabin. If existing wires can be used for these EDC signals, the seals for a pressurized cabin do not have to be disturbed.

If fuel levels are to be monitored using the aircrafts existing resistive fuel sensor, an RFLM (Resistive Fuel Level Module) will need to be installed. This module provides the pull-up current necessary to operate the resistive sensors. The RFLM-4-xx can handle up to four fuel tanks.

E. The two MVP displays will be installed in the instrument panel on the same horizontal plane and within 2 inches of each other. For an aircraft with the engines mounted in the front and back of the cabin (push-pull), the MVPs will be installed on the same vertical plane.

Each MVP can be mounted one of two ways: from behind the instrument panel or on a sub-panel, which is then mounted to the aircraft instrument panel from the front. This former method hides the cutout for the MVP case and makes a clean and good-looking installation. Electronics International has a MVP sub-panel available (see E.I. Price List for more information).

F. Any Control Panels and Warning Lights will be installed.

G. The MVP wire harnesses will be installed. Refer to the MVP wire harness diagram provide with each wire harness.

H. MVP setup and field calibration will be performed (Weight & Balance, Fuel Tank Cal, Horsepower, etc.).

I. System Checkout will be performed.

1.2 Password Protection:

The MVP provides a number of screens for the pilot to use during flight, none of which require a password. It also provides many System Configuration Screens that are used to configure the MVP for a specific aircraft. Some of the aircraft functions (fuel level, flaps, trim, weight and balance, etc.) must be calibrated during installation and some are set at the factory or by an OEM.

The MVP provides two levels of passwords for configuring and calibrating the unit.

1.2.1 Level #1 Password (Maintenance):

The Level #1 password is for the installer or maintenance personnel. This password allows the installer to perform the following:

- A. Delete Log Files.
- B. Set up the Gear Warning.
- C. Adjust the Recovery Factor.
- D. Calibrate the Fuel Level for all Fuel Tanks.
- E. Adjust the Aircraft's Weight and Balance data.
- F. Set the Fuel Weight, Tach Time and Engine Hours.
- G. Set up the Serial Ports.
- H. Disable the Bar Graph.
- I. Calibrate Pressure Altitude.
- J. Calibrate Flap and Trim indications.

For a non-certified MVP, the password is “00100.” For a certified MVP the password must be obtained from Electronics International Inc. To qualify for the maintenance password you must be a certified mechanic or a FAA approved shop.

The password protects the MVP from unauthorized access to calibration data. If calibration data is improperly changed, it could lead to engine or aircraft damage and/or personal injury. Once the MVP is installed and checked out, the password should be changed (on either the certified or non-certified unit) to a unique number and it should be protected from unauthorized access.

If the new password is lost or a new shop requires access to calibration data (as allowed by the Maintenance Password), Electronics International has a method of providing the Maintenance Password to any FAA authorized shop or certified mechanic.

1.2.2 Level #2 Password (OEM/Experimental):

The Level #2 password is for the Factory, OEM’s, Certified Installers, or experimental users. This password allows access to all System Configuration Data. For a non-certified MVP, the password is “00100.” For a certified MVP the password is only released under a contract or agreement.

The password protects the MVP from unauthorized access to calibration data. If calibration data is improperly changed, it could lead to engine or aircraft damage and/or personal injury. Once the unit is installed and checked out, this password should be changed (whether a certified or non-certified MVP) to a unique number and should be protected from unauthorized access.

Blank Page

Hardware Installation

2.1	Important Information and Initial Checkout: -----	13
2.2	Review the "EDC Wiring Work Sheets:" -----	14
2.3	Verify You Have all the Probes, Modules, Transducers and Cables: -----	14
2.4	Install the MVP Displays: -----	14
2.5	Install the Temperature Probes: -----	15
2.6	Install the Pressure Transducers: -----	18
2.7	Install the Interface Circuit for Annunciators: -----	21
2.8	Install the Interface Circuit for a PWM Backlight System (Optional): -----	21
2.9	Install the Interface Circuit for Flap and Trim Pots (OEM / Experimental):-	22
2.10	Install the Interface Circuit for Gear Position, Unsafe Indicator & Gear Warning:-	22
2.11	Install the G-Sensor and/or Other Available MVP Options: -----	23
2.12	Install the Shunts: -----	23
2.13	Install the Fuel Flow Transducers: -----	26
2.14	Install the EI P-300C Fuel Level Probes (OEM or Experimental Only): ----	32
2.15	Install the EI P-300M Magnetic Fuel Level Senders: -----	32
2.16	Install the Resistive Fuel Level Module (RFLM-4-X): -----	33
2.17	Install the Intensity Control Pot (Optional): -----	33
2.18	Install the Master Warning (red) and Caution (yellow) Lights: -----	34
2.19	Install the USB-6A (Optional): -----	34
2.20	Install any Additional Modules (Optional): -----	34
2.21	Installing the EDC-33Ps: -----	34

Blank Page

2.1 Important Information and Initial Checkout:

- A. **The installer and aircraft owner must read the Warranty/Agreement before starting the installation.** There is information in the Warranty/Agreement that may alter your decision to install this instrument. **If you do not accept the terms of the Warranty/Agreement, do not install this instrument.**
- B. **If you are not an FAA Certified Aircraft Mechanic familiar with the issues of installing engine and aircraft instruments, Do not attempt to install this instrument. The installer should use current aircraft standards and practices to install this instrument (refer to AC 43.13).**
- C. **Check that any necessary FAA Approvals are available for your aircraft before starting the installation. The STC and AML is located in section 8 of this manual.**
- D. Read the Installation Instructions entirely and resolve any issues you may have **before** starting the installation. This may eliminate any delays once the installation is started.
- E. Inspect the contents of this package prior to installation. **If the MVP-50P system is to be installed into a certified aircraft, check that the Model Number listed on the TSO label incorporates the Aircraft ID for which it is to be installed. Each MVP-50P display is configured for a specific aircraft and should ONLY be installed in that aircraft.**
- F. **Do not install a non-certified MVP in a certified aircraft.** A certified MVP lists the applicable TSO numbers at the bottom of the Model Label attached to the back panel of the MVP.
- G. **Before starting the installation make sure the instruments will fit in the intended installation location without obstructing the operation of any controls.** CFR 23.1321(a) states, "Each flight, navigation, and powerplant instrument for use by any required pilot during takeoff, initial climb, final approach, and landing must be located so that any pilot seated at the controls can monitor the airplane's flight path and these instruments with minimum head and eye movement." AC 23.1311-1B provides one method (but not the only method) of complying with the is CFR. AC 23.1311-1B recommends a powerplant instrument be installed within a distance of 21" from the pilot's visual centerline to the middle of the instrument. The pilot's visual centerline is a perpendicular line from the pilot's eye to the instrument panel. In most aircraft, installing the MVP-50P to the right of the Radio Stack would be acceptable. In some aircraft, the visual centerline falls to the right of the Attitude Indicator.

If the powerplant instrument cannot be installed within 8" of the pilot's visual centerline, AC 23.1311-1B recommends Master Caution and Warning Lights be installed. Installation of Master Caution and Warning Lights is covered in this manual.
- H. Installing the MVP-50Ps may require an instrument (or two) to be moved to a new location. Each MVP-50P replaces eight or more primary instruments in the aircraft instrument panel, therefore moving an instrument to a new location may not be an issue. If the installer is unwilling or unable to find a location for the MVP-50Ps, **Do Not Install** the MVP-50Ps. The system may be returned for a refund.
- I. The MVPs will replace existing gauges in the aircraft, it is the installer's responsibility to replace any existing instruments or components in accordance with FAA approved methods and procedures (see AC 43.13).
- J. An Installation Checklist is provided to assist the installation of the MVP system. It does not replace the instructions located in this manual.

2.2 Review the "EDC Wiring Work Sheets:"

There are a number of probes and extension cables that will need to be installed. The key to keeping the installation simple is to organize the work using the "EDC Wiring Work Sheets" supplied with this kit. Review the functions assigned to each EDC input on the EDC Wiring Work Sheets and identify the probes and/or transducer for each. The work sheets are prepared at the factory with the functions and probes already assigned.

2.3 Verify You Have all the Probes, Modules, Transducers and Cables:

The EDC 37-pin D-sub connectors and the MVP 25-pin D-sub connectors are pre-wired at the factory. Each EDC has three connectors which are marked Top, Middle and Bottom. The EDC Wiring Work Sheets provide a list of the probes supplied with this kit.

- A. Check that you have all the probes listed on the EDC Wiring Work Sheets.
- B. Check that each EDC has three EDC 37 pin-D-sub wire harnesses (Top, Middle and Bottom) and with the proper wires for each of the probes shown on the EDC Wiring Work Sheets. Some wires must be supplied by the installer.
- C. Check that a MVP 25-pin D-sub wire harness is provided for each MVP.

2.4 Install the MVP Displays:

Before starting the installation make sure the instruments will fit in the location you intend to install them without obstructing the operation of any controls. Also, the pilot should have a clear view of the MVP displays without any visual obstructions. The MVP displays can be installed in one of two ways, depending on convenience or the installer's preference. The first method is the traditional method of installing the MVP display from behind the panel. An aircraft panel cutout drawing is provided at the back of this manual.

The second method is more suitable when an MVP display is to be mounted in an existing aircraft panel. This method requires creating a sub-panel slightly larger than the MVP display. The MVP display is mounted in the sub-panel and the sub-panel is mounted on the front of the existing aircraft panel. This allows the installer to rough-cut a hole in the aircraft panel to accommodate the MVP displays. The sub-panel covers any imperfections in the cut hole. Also, the MVP displays may easily be removed from the front of the aircraft panel. Electronics International has a pre-cut MVP Sub-panel available. See EI's Price List or contact EI for more information.

The sub-panel should be made from .062" (or thicker) aluminum and can be painted black or the same color as the aircraft panel. Four screws (6-32 or larger) to be located at the top and bottom of the sub-panel should be drilled to mount the sub-panel to the aircraft panel. If there is no room at the top and bottom for mounting screws, they may be placed on the sides of the sub-panel.

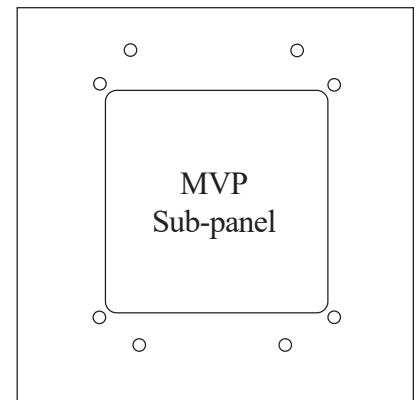

Orientation: The two MVP displays must be installed in the instrument panel aligned horizontally (i.e.: the top of the MVPs case must be level) and within 2 inches of each other. If the MVPs are centered over two side-by-side radio stacks, they may be installed further than 2 inches from each other. For an aircraft with the engines mounted in the front and back of the cabin (push-pull), the MVPs must be aligned vertically.

If the current RPM or Manifold Pressure gauges in the aircraft are mounted above and below each other, the MVPs may also be mounted on the vertical plane (above and below each other).

Left and Right MVPs: One MVP is labeled LEFT and one is labeled RIGHT. Only the LEFT MVP will provide those functions that cannot be designated left or right (i.e.: Bat Volts, Bat Amps, Vacuum, Aux Fuel, etc.). For a push-pull aircraft the MVPs will be labeled FRONT and BACK. Only the FRONT MVP will provide those functions that cannot be designated front or back (i.e.: Bat Volts, Bat Amps, Vacuum, Aux Fuel, etc.). Make sure the MVPs are installed correctly in the aircraft panel (in accordance with these labels) .

Panel Placement: CFR 23.1321(a) states, “Each flight, navigation, and Powerplant instrument for use by any required pilot during takeoff, initial climb, final approach, and landing must be located so that any pilot seated at the controls can monitor the airplane’s flight path and these instruments with minimum head and eye movement.” AC 23.1311-1B provides one method (but not the only method) of complying with this CFR. AC 23.1311-1B recommends a Powerplant instrument be installed within a distance of 21" from the pilot’s visual centerline to the middle of the right most MVP-50 display. The pilot’s visual centerline is a perpendicular line from the pilot’s eye to the instrument panel.

If the powerplant instrument cannot be installed within 8" of the pilot’s visual centerline, AC 23.1311-1B recommends Master Caution and Warning Lights be installed. Installation of Master Caution and Warning Lights is covered in this manual.

Installing the MVP-50P may require an instrument (or two) to be moved to a new location. Each MVP-50P replaces eight or more primary instruments in the aircraft instrument panel, therefore moving an instrument to a new location may not be an issue. If the installer is unwilling or unable to find a location for the MVP-50Ps, **Do Not Install** the MVP-50P. The system may be returned for a refund (contact EI for more information).

2.5 Install the Temperature Probes:

Install only the Temperature Probes applicable for your configuration.

A. EGT Probe Installation:

Look at each exhaust stack and determine the best location at which all of the EGT probes can be mounted at the same distance down from the exhaust ports. The ideal location is 2"-4" for a normally aspirated engine and 4"-6" for a turbo charged engine, but ease of installation should prevail. For fast response probes (P-110F) drill a 5/32" diameter hole in each exhaust stack. For robust probes (P-110R), drill a 13/64" diameter hole in each exhaust stack. Insert the probe and tighten the hose clamp. As the hose clamp is heated and cooled, it will become loose as it conforms to the exhaust stack. After the first 10 hours of operation, each hose clamp should be retightened.

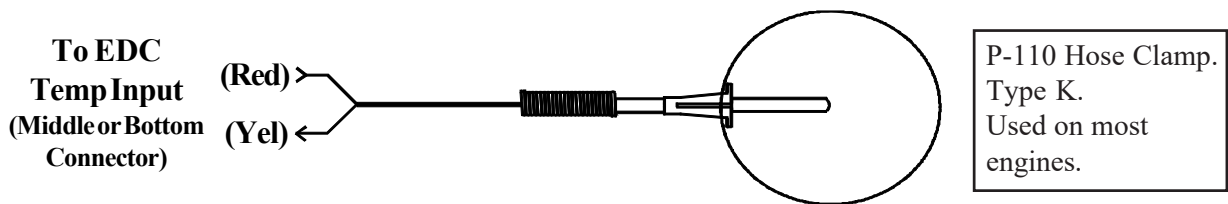

IMPORTANT NOTE: For Cessna 210s or any aircraft having a slip joint in the exhaust system, install the EGT probes ABOVE OR BELOW THE SLIP JOINT. Installing an EGT probe in the slip joint can damage the probe.

B. TIT Probe Installation:

The TIT probe should be installed on the inlet of the Turbocharger one to two inches before the Turbocharger flange. Look at each exhaust stack and determine the best location to install the TIT probe. It should be routed away from the exhaust pipe and should not come in contact with other aircraft components. When installing the P-110 probe, drill a 13/64" diameter hole in the exhaust stack. Insert the probe and tighten the hose clamp.

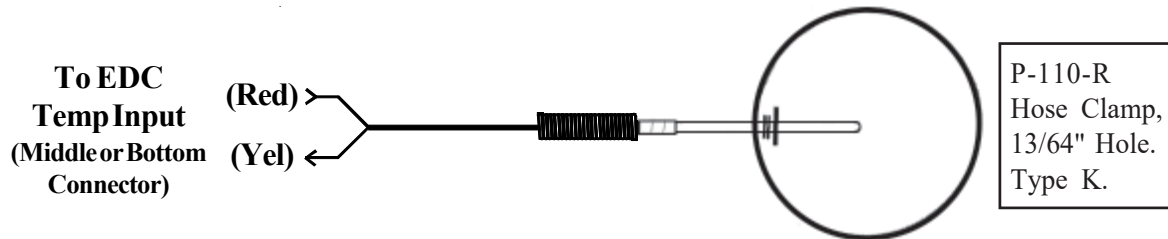

If a P-111, P-112 or P-114 TIT probe is to be installed, perform the steps outlined in the "TIT Probe Depth Adjustment Procedure" that comes with the TIT probe.

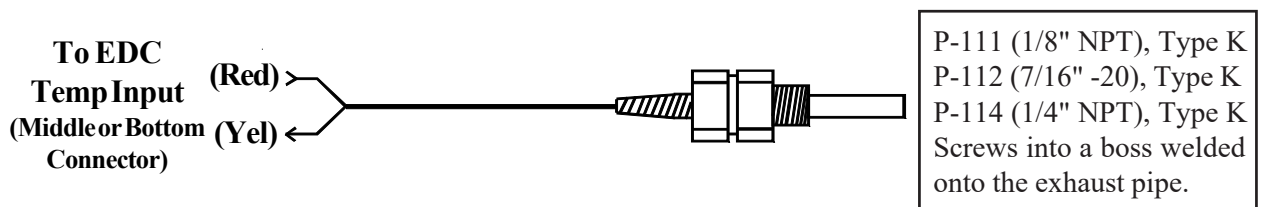

NOTE: After the first 10 hours of operation, the hose clamp on the P-110 probe should be retightened. As the hose clamp is heated and cooled, it will become loose as it conforms to the exhaust stack.

C. CHT Probe Installation:

Most engines have threaded ports for the CHT probes just below the lower spark plug. Install the CHT probes into these threaded ports.

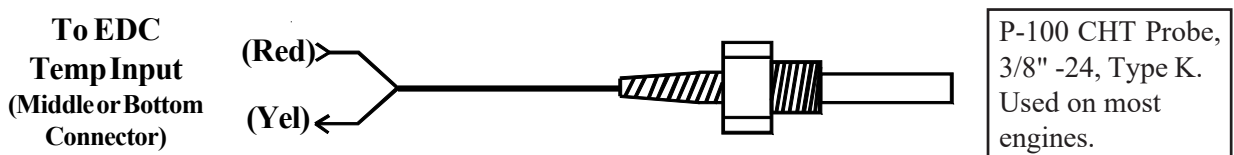

D. OIL Temperature Probe Installation:

Oil temperature can vary throughout an engine. Your engine's oil temperature specifications are based on a specific location of the oil temperature probe. If the MVP is to be used as the primary oil temperature instrument, install the oil temperature probe (P-120) in the primary oil temperature pick up point for your engine.

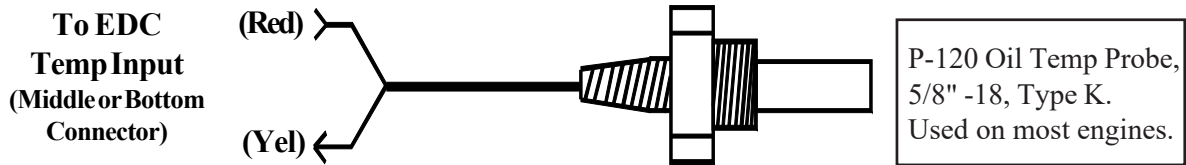

E. Carb Temp Probe Installation:

Remove the threaded plug located in the carburetor housing just below the throttle valve. Install the Carburetor Temperature Probe (P-128) in this hole using a lock washer. Care should be taken not to over-tighten the probe, thereby stripping the threads in the carburetor housing.

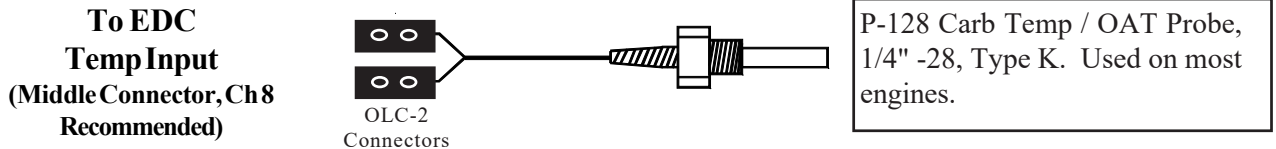

F. OAT Probe Installation:

Mount the OAT Probe in an appropriate location on the aircraft, using the hardware supplied. The OAT Probe is sensitive to air temperature changes. For this reason, do not mount the OAT probe in the path of the cowl or engine exiting air (i.e., on the belly of the aircraft). Also, if the probe is mounted in the cowling area near a turbo or hot cylinder head, radiant heat may influence the probe temperature. Other than these considerations, the OAT Probe may be mounted in an air intake vent, on the side of the cowling or anywhere else on the aircraft.

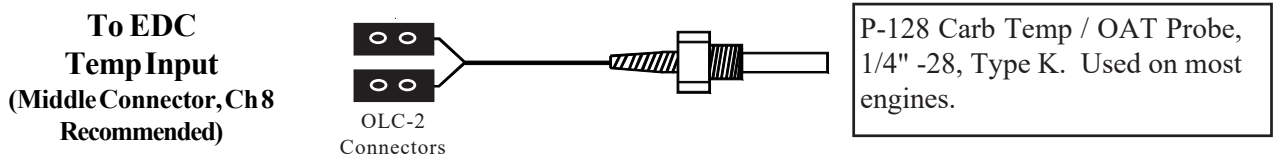

G. Other Temperature Probe Installation:

Other temperature probes (Cowl Temp, CDI Temp, Water Temp, etc.) may be installed using current aircraft standards and practices (refer to AC 43.13). Make sure these probes do not interfere with the operation of the engine or aircraft.

2.6 Install the Pressure Transducers:

Install only the Pressure Transducers applicable for your configuration.

A. Manifold Pressure Transducer Installation:

Mount the two PT-30ABS Manifold Pressure Transducers under the instrument panel or in an equipment bay or in nacelle. Use the holes in the bottom plate to mount the PT-30ABS. Only two mounting screws are required.

An equipment bay can be made from a sheet of aluminum. Any piece of equipment or module used with the MVP-50P can be mounted on the aluminum sheet using a Nut Plate or Riv-Nut to allow easy installation and removal. The aluminum sheet is then mounted to the inside firewall of the aircraft (using short spacers) and should never have to be removed. Many aircraft are designed with an equipment bay.

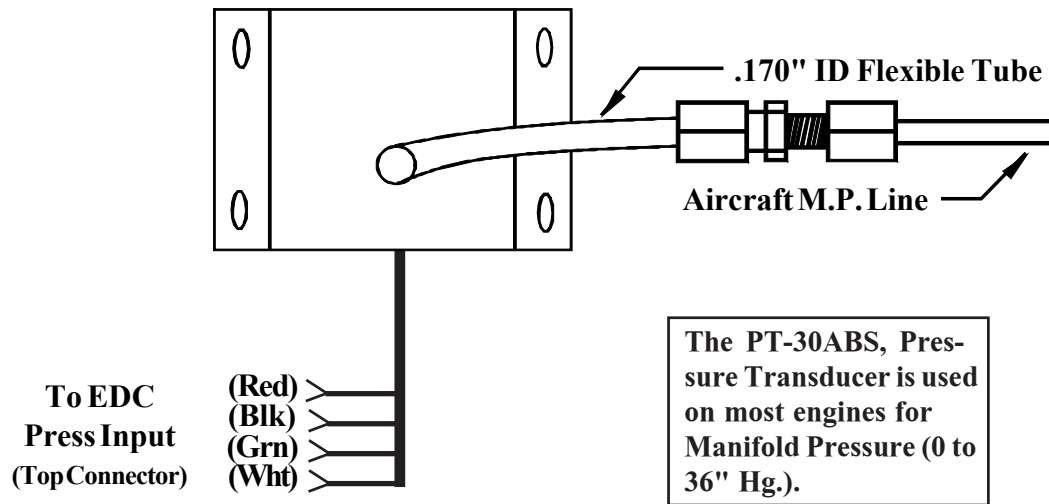

Connect the aircraft manifold pressure line to the pressure port on the PT-30ABS Pressure Transducer. A flare or barb fitting may be used to connect these lines. Care should be taken not to put excess pressure on the flexible line between the union and the pressure transducer. **Make sure there are no kinks in the flexible pressure line.**

Note: Many certified aircraft have a very small hole in the manifold pressure line to create airflow back to the intake manifold. This small flow of air keeps fuel from working its way into the manifold pressure gauge (or in this case the transducer), which can cause damage to the transducer over time.

Note: The PT-30ABS can measure manifold pressure up to 36.0" Hg. For manifold pressures above 36.0" Hg. use the PT-60ABS or PT-200ABS pressure transducer.

B. Gyro Vacuum Pressure Transducer Installation:

Mount the PT-05Diff Pressure Transducer under the aircraft instrument panel or in the equipment bay or in nacelle. Use the holes in the bottom plate to mount the PT-05Diff. Only two mounting holes are required. Connect the aircraft gyro vacuum line to the port tagged “Low” on the PT-05Diff. Connect the port tagged “High” to the aircraft overboard pressure line. A flare or barb fitting may be used to connect these lines. Care should be taken not to put excess pressure on the flexible line leading to the pressure transducer.

Make sure there are no kinks in the flexible pressure lines.

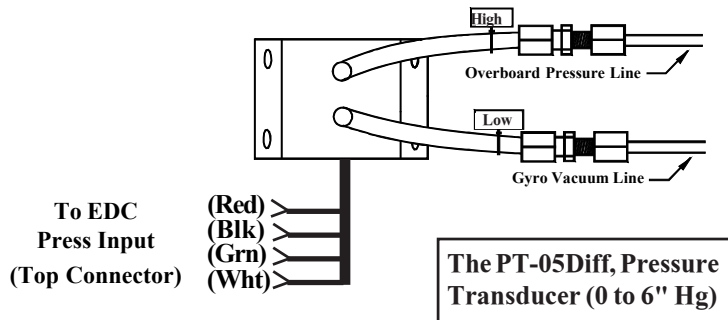

C. Oil Pressure Transducer Installation:

Find a convenient location on the firewall or a bracket and mount the pressure transducer with the clamp provided. The oil pressure line does not have to be routed into the cabin area, although you will need access on the back side of the firewall to tighten the pressure transducer clamp nut. **Do not mount the pressure transducer to an engine baffle or directly on the engine with the transducer supported by an adapter or fitting.** Vibration can cause the adapter to break, resulting in loss of engine oil. The pressure transducer is equipped with an 1/8" NPT male port. This port can be adapted to any oil pressure line. Use only a flexible hose and fittings suitable for aircraft use. Route a flexible oil pressure line from the primary oil pressure pickup point to the pressure transducer and tighten all fittings. **Do not use the case of the pressure transducer to tighten the pressure fittings.** Maintain any restrictive orifice currently in the system.

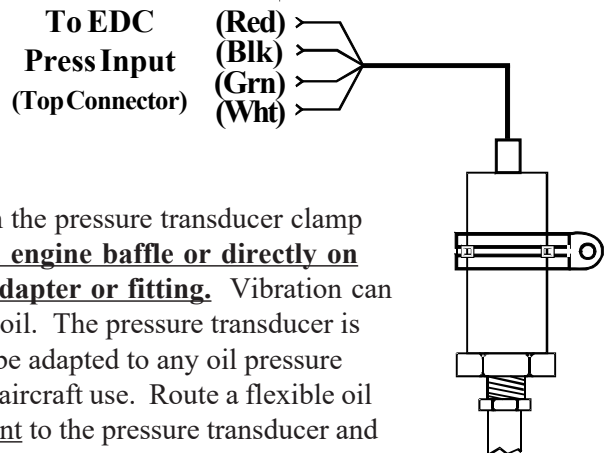

The PT-100GA Pressure Transducer is used on most engines for pressures up to 115 psi.

Some fittings you may want to consider using are listed below:

Important Note: Aluminum fittings should only be used when flex lines are mounted on the inlet and outlet ports of the flow transducer. Otherwise, steel, SS or brass fitting should be used.

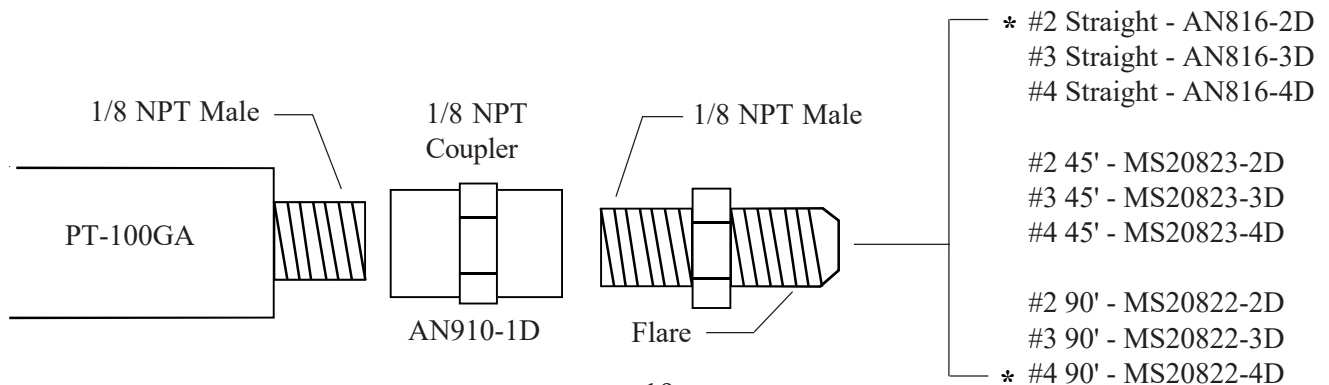

D. Fuel Pressure Transducer Installation:

Find a convenient location on the firewall or a bracket and mount the pressure transducer with the clamp provided. The fuel pressure line does not have to be routed into the cabin area although you will need access to the back side of the firewall to tighten the pressure transducer clamp nut. **Do not mount the pressure transducer to an engine baffle or directly onto the engine with the transducer supported by an adapter or fitting.** Vibration can cause the adapter to break, resulting in loss of engine fuel. The pressure transducer is equipped with a 1/8" NPT male port. This port can be adapted to any fuel pressure line. Use only a flexible hose and fittings suitable for aircraft use. Route a flexible fuel pressure line from the primary fuel pressure pick up point to the pressure transducer and tighten all fittings. **Do not use the case of the pressure transducer to tighten the pressure fittings.** Maintain any restrictive orifices currently in the system.

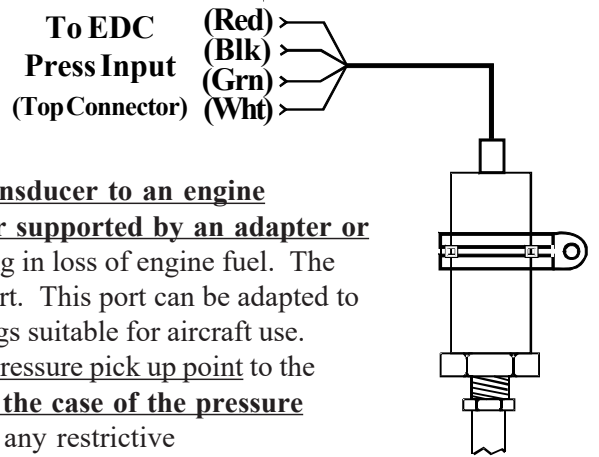

The PT-30GA Pressure Transducer is used on most engines for pressures up to 35 psi.

See previous page to view.

* Some fittings you may want to consider using are listed above.

E. Airspeed Transducer Installation:

Mount the PT-05Diff Pressure Transducer in the cabin under the instrument panel or in the equipment bay or nacelle. Use the holes in the bottom plate to mount the PT-05Diff. Only two mounting holes are required.

Connect the aircraft pitot (airspeed) line to the port tagged "High" on the PT-05Diff. Connect the aircraft static pressure line to the port tagged "Low" on the PT-05Diff. A flare or barb fitting may be used to connect these lines. Care should be taken not to put excess pressure on the flexible lines. **Make sure the flexible lines do not kink.**

To EDC
Press Input

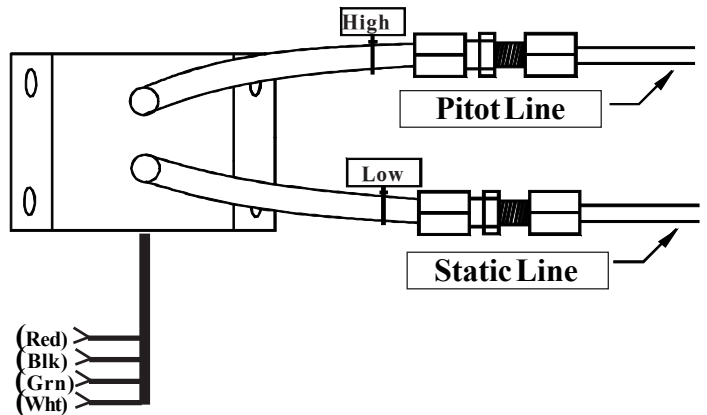

F. Altitude Transducer Installation:

Mount the PT-30Alt Altitude Transducer in the cabin under the instrument panel or in the equipment bay. Use the holes in the bottom plate to mount the PT-30Alt. Only two mounting holes are required.

Connect the aircraft static line to the port on the PT-30Alt. A flare or barb fitting may be used to connect these lines. Care should be taken not to put excess pressure on the flexible line. **Make sure the flexible line does not kink.**

To EDC
Press Input
(Top Connec-

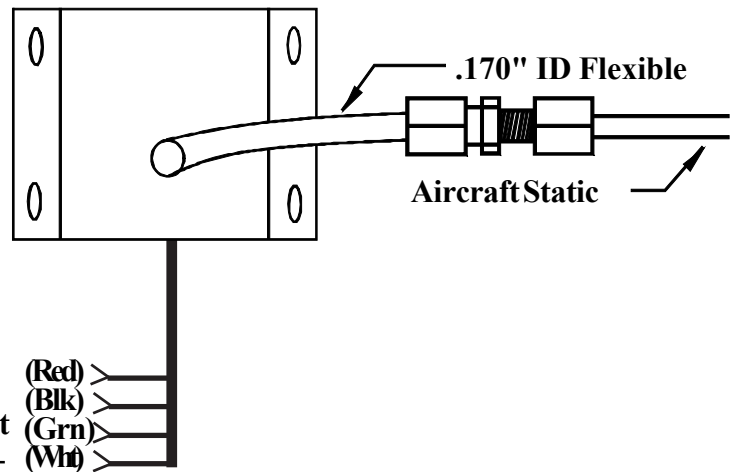

G. Other Pressure Transducer Installations:

Other pressure transducers should be mounted in the aircraft in the same manner as the Gyro Vacuum Transducer or the Oil and Fuel Pressure Transducers, as appropriate. **Note:** Any unused + or - pressure inputs on the EDC must be wired to a ground pin on the EDC 37-pin connector.

2.7 Install the Interface Circuit for Annunciators:

Any Temperature or Resistive Fuel Level channel on the EDC may be used to monitor the state of a switch, relay or output from a device. This output can be used to trigger a light (annunciator) on the MVP. Annunciator lights such as Canopy Latch, Baggage Door, Deice, Pitot Heat, Fire, etc. can be displayed on the Main or System screen on the MVP.

To monitor a voltage, a VI-221 (Voltage Interface Unit) will be required. This consists of a 221K ohm resistor heat shrunk between two wires with a D-Sub pin crimped on one end. The following methods may be used to interface an EDC channel (using a VI-221) to a switch, relay or device:

A. Monitoring a Signal That Switches Between Any Voltage and Ground:

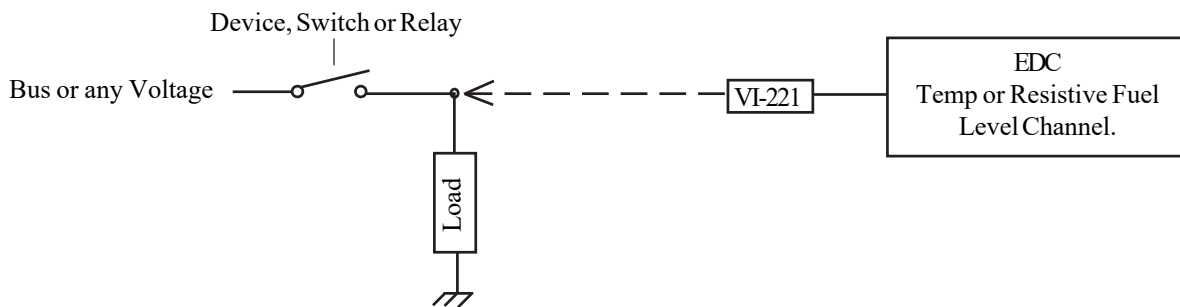

B. Monitoring a Signal that is Switched to Ground:

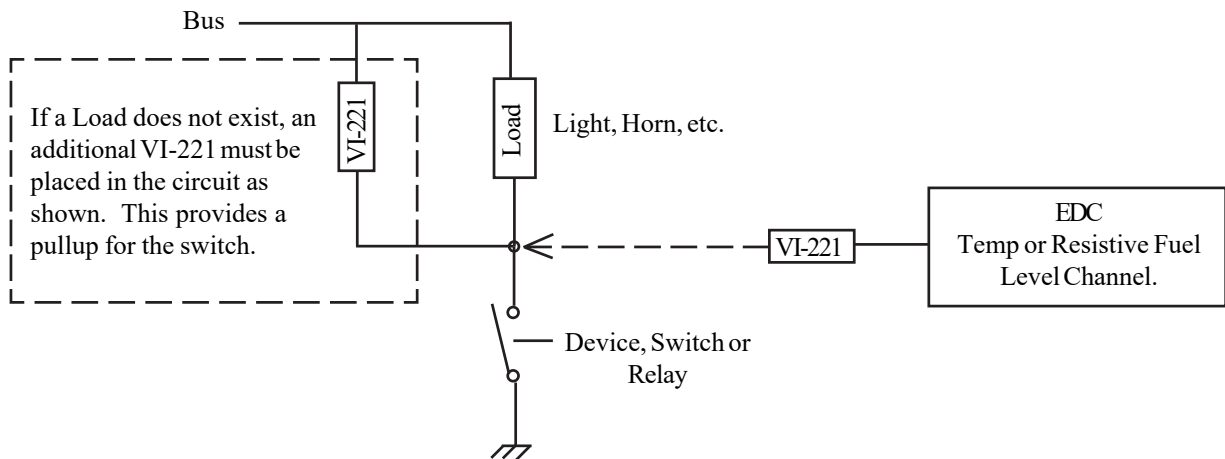

2.8 Install the Interface Circuit for a PWM Backlight System (Optional):

If a PWM backlight system will be used to control the MVP-50 screen intensity, place the following circuit in series with the MVP-50 backlight wire.

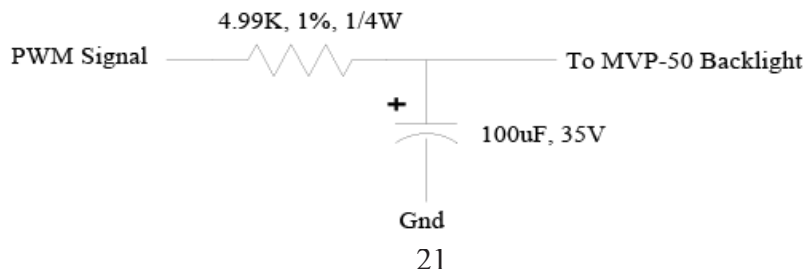

2.9 Install the Interface Circuit for Flap and Trim Pots (OEM / Experimental):

Elevator, Aileron and Rudder trim (as well as Flap position) can be monitored and displayed on the MVP. In most cases the position of these surfaces are monitored using a mechanical 5K ohm pot. The following circuit may be used to interface with a 1K to 100K pot.

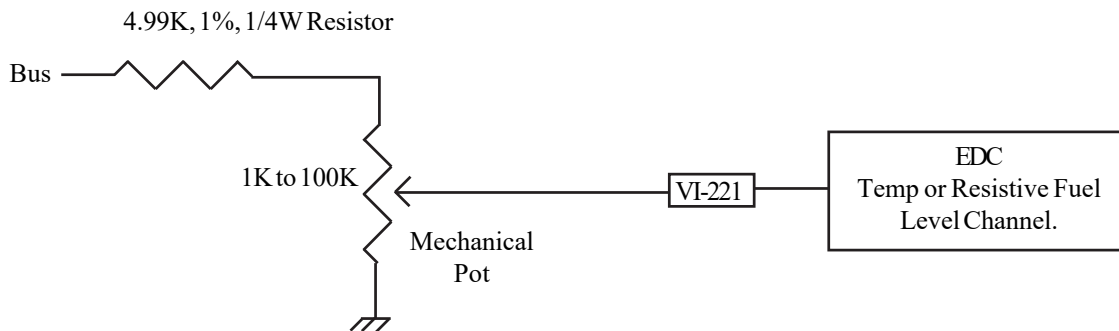

2.10 Install the Interface Circuit for the Gear Position, Unsafe Indicator and Gear Warning:

The Gear Position and Unsafe Indicator shown on the MVP System Screen is intended as a backup to the aircraft's existing system. The Gear Warning operates off the Gear Position, Unsafe Indicator, Airspeed and Manifold Pressure. The Gear Warning provides a voice warning to reduce the possibility of gear up landings. Voice warnings are NOT available for certified aircraft at this time.

Unsafe Indicator: Operates from an unsafe signal from the aircraft. Displays as either Red or Off on the MVP. The EDC interface circuit is shown below. The Unsafe Indicator is REQUIRED with any landing gear options listed below and requires one EDC input.

Landing Gear Position: There are three options for interfacing the EDC to the aircraft's gear system, all of the options below require the Unsafe Indicator (see above).

Option 1: Connect the EDC to the aircraft's Right, Left and Nose Gear green down lights. The state of each gear will be displayed independently on the MVP. Select Gear Left, RT and Nose for the probes in Configuration Screen #1. This option requires three EDC inputs. The EDC interface circuit is shown below.

Option 2: Connect the EDC to the aircraft's Nose Gear green down light. The state of all three gears will be displayed on the MVP based on the Nose Gear's state. Select "Gear All" for the probe in Configuration Screen #1. This option requires one EDC input. The EDC interface circuit is shown below.

Option 3: Use this option to display only the Left and Right Main Gears (no Nose Gear) from a single input. Connect the Left or Right Main Gear to the EDC as shown below. Select "Gear Main" for the probe in Configuration Screen #1. This option requires one EDC input. The EDC interface circuit is shown below.

Note: When setting colors, use Green for down and White for up. Red will cause an error.

Gear Up Warning: To provide a Gear Warning the MVP must monitor Gear Position, Airspeed and Manifold pressure. A voice warning (for experimental aircraft only) is activated on the following logic:

(Any Gear is up **-OR-** the Unsafe Indicator is on) **-AND-** Airspeed is less than a set value **-AND-** Manifold Pressure is less than a set value.

Note: See the “Aircraft Number, Gear Warning and TAS Setup” screen to set values.

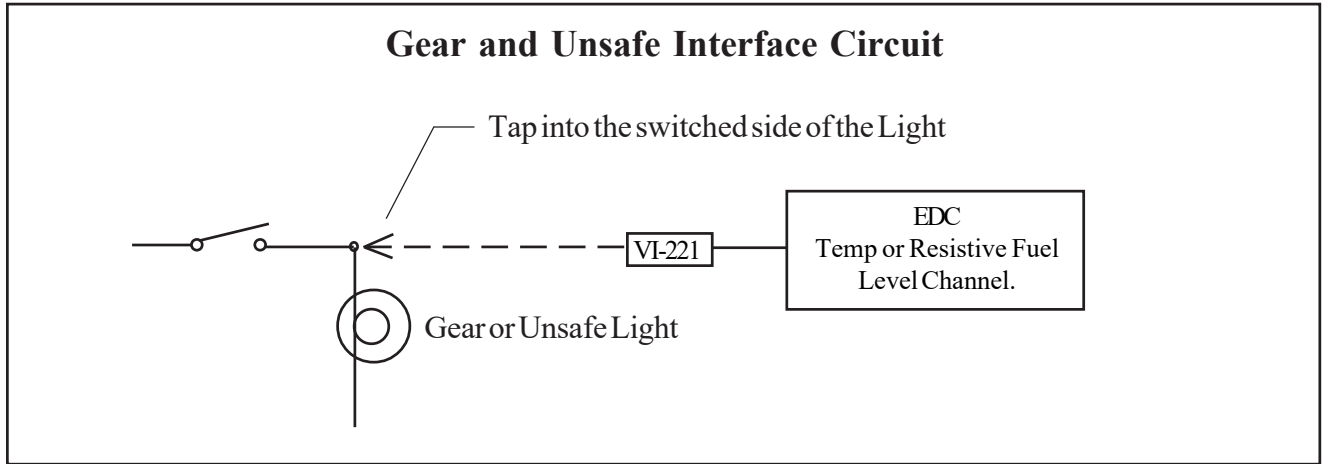

2.11 Install the G-Sensor and/or Other Available MVP Options:

The G-Sensor and other MVP options listed on the EI’s price sheet are provided with their own installation instructions. These items should be installed and wired in accordance with the accompanying instructions.

2.12 Install the Shunt:

An external shunt is a strip of metal, usually mounted on a bakelite base. This metal is made of special alloys to produce a very small, precise signal when current passes through it. It is not affected by temperature changes. If your aircraft currently has an external shunt you can calibrate your MVP to that shunt. The MVP can be calibrated to match any shunt on the market.

A. Determine How the Shunt will be Installed in the Aircraft’s Electrical System:

There are two common methods of installing a shunt in an aircraft. One method is with the shunt in the alternator lead. The other method is with the shunt located in the battery lead. The S-50 shunt that comes with the MVP-50 package may be installed using either method. The advantages and disadvantages of each method are listed here to the below right.

There are few disadvantages with either method. Although EI’s test pilot has a slight preference for the alternator lead when using the MVP, ease of installation should be the determining factor in this installation. If more than one shunt is required, a second shunt can be installed through a FM-VA-M-(50 or 300) Functional Module. The Functional Modules come with their own installation instructions.

Installation Method	Advantages	Disadvantages
Battery Lead:	<ol style="list-style-type: none"> Shows load current on the ground (engine off) and during an alternator failure. All Warning Lights are operational. 	<ol style="list-style-type: none"> Cannot show load current during flight or when the engine is running.
Alternator Lead:	<ol style="list-style-type: none"> Shows load current during flight or when the engine is running. All Warning Lights are operational. 	<ol style="list-style-type: none"> Cannot show load current when the engine is off or during an alternator failure.

S0224921

B. Install the External Shunt:

The external shunt should be installed in an appropriate location that minimizes the routing of main cables (refer to figure 1 or 2 as appropriate for your installation). It should also be mounted in a location where inadvertent damage cannot occur. If the shunt can be accessed easily, it should be covered. When mounting the shunt, use self-locking or safety-wired nuts.

The signal wires from the shunt to the EDC must be fused a short distance after they leave the shunt. If this is a new installation, install two in-line one-amp fuses, one in each of the signal lines from the shunt to the EDC Amp Input.

Note: If you are replacing an existing ammeter, the shunt may already be mounted in the aircraft. If you already have a shunt installed and know the value of the existing shunt, the MVP can be calibrated to that shunt.



Shunt

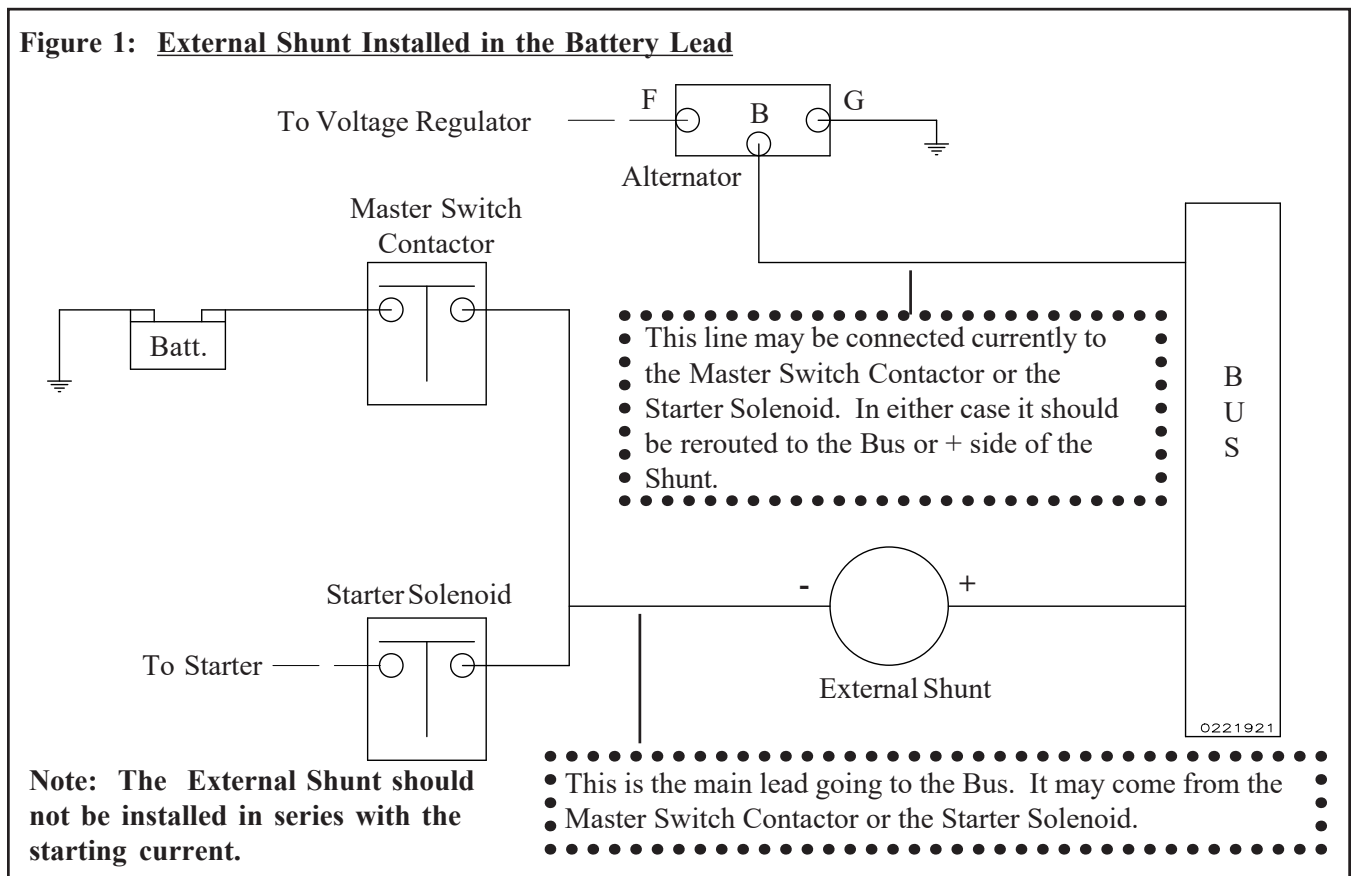
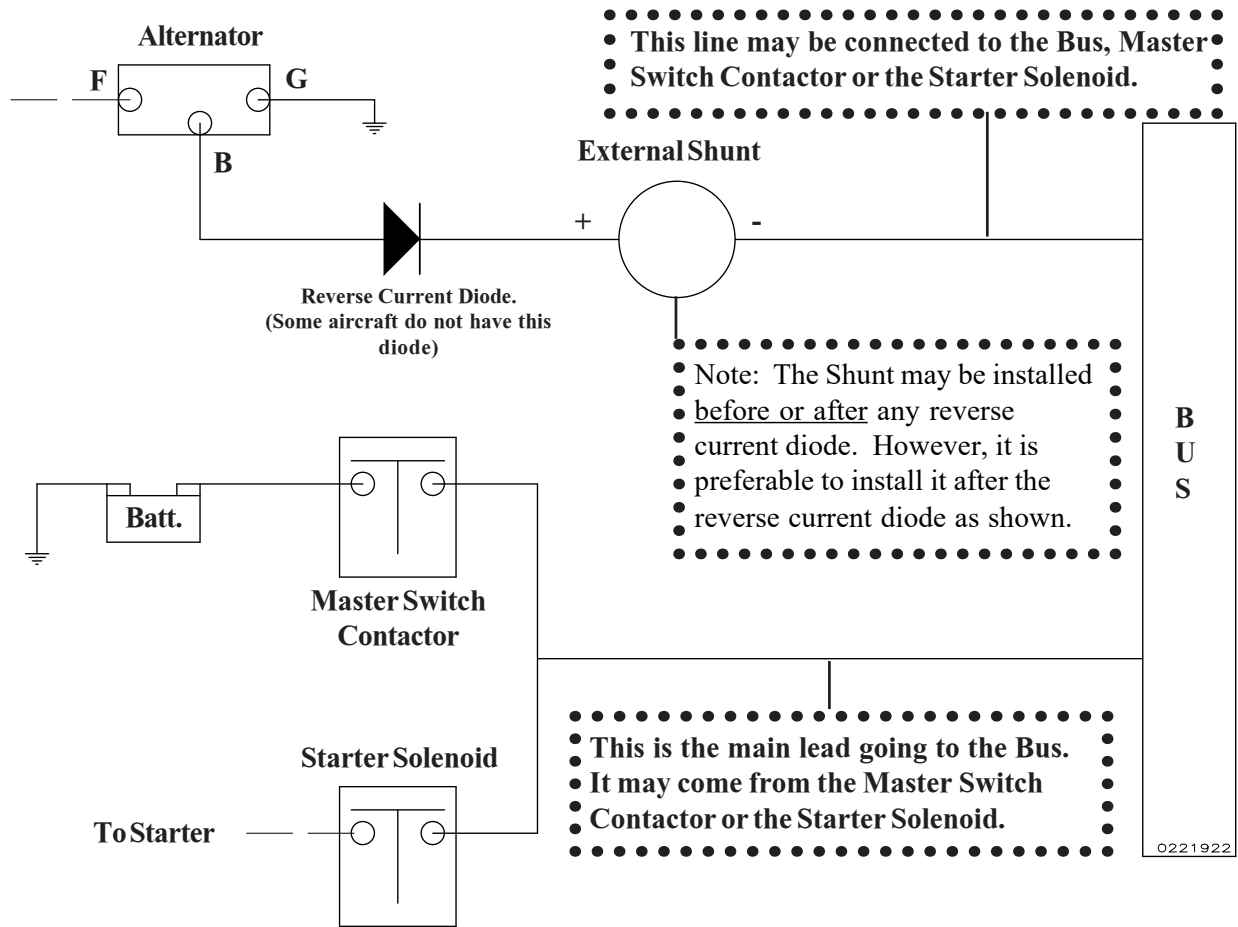

Figure 2: External Shunt Installed in the Alternator Lead



2.13 Install the Fuel Flow Transducers:

Mount the Fuel Flow Transducers using the appropriate drawing found on the following pages.

<i>Aircraft Configuration</i>	<i>Drawing #</i>
Fuel injected engine without a fuel return line from the fuel servo (most Lycomings).	1229932 or 1229931
Fuel injected engine with a fuel return line from the fuel servo (most Continentals).	0415941
Carbureted engine with a fuel pump and no fuel return line.	1229932 or 1229931
Carbureted engine with a fuel pump and a fuel return line (requires an FFDM-1 Module).	1229932 or 1229931, and 1015941
Carbureted engine with a gravity feed fuel system (requires an FT-90 Flow Transducer).	1229932 or 1229931

Fuel Flow Transducer Selection:

FT-60 (Red Cube): For 0 to 350 HP Engines.

FT-90 (Gold Cube): For 350 to 550 HP Engines.

FT-180 (Black Cube): For 550+ HP Engines.

(See the transducer specification for pressure drops at a given flow rate.)

Note: If your engine is equipped with a pressure carburetor with a fuel return line from the carburetor back to the fuel tank, you will need to install two flow transducers for each engine: one in the feed line from the fuel pump to the carburetor and one in the return line from the carburetor back to the fuel tank. Also, two Fuel Flow Differential Modules (FFDM-1) will need to be installed. See drawings 1229932 and 1015941 on the following pages.

Note: Insure the fuel flow transducers are appropriate for the horsepower of the engine.

A. The transducer output port should be mounted lower, even with or no more than 4" per foot higher than the carburetor inlet port (or fuel servo on a fuel-injected engine). If this is not possible, a loop should be put in the fuel line between the Fuel Flow Transducer and the carburetor or fuel servo (see diagram below). This loop is intended to vacate air and keep it from getting trapped in the fuel transducer.

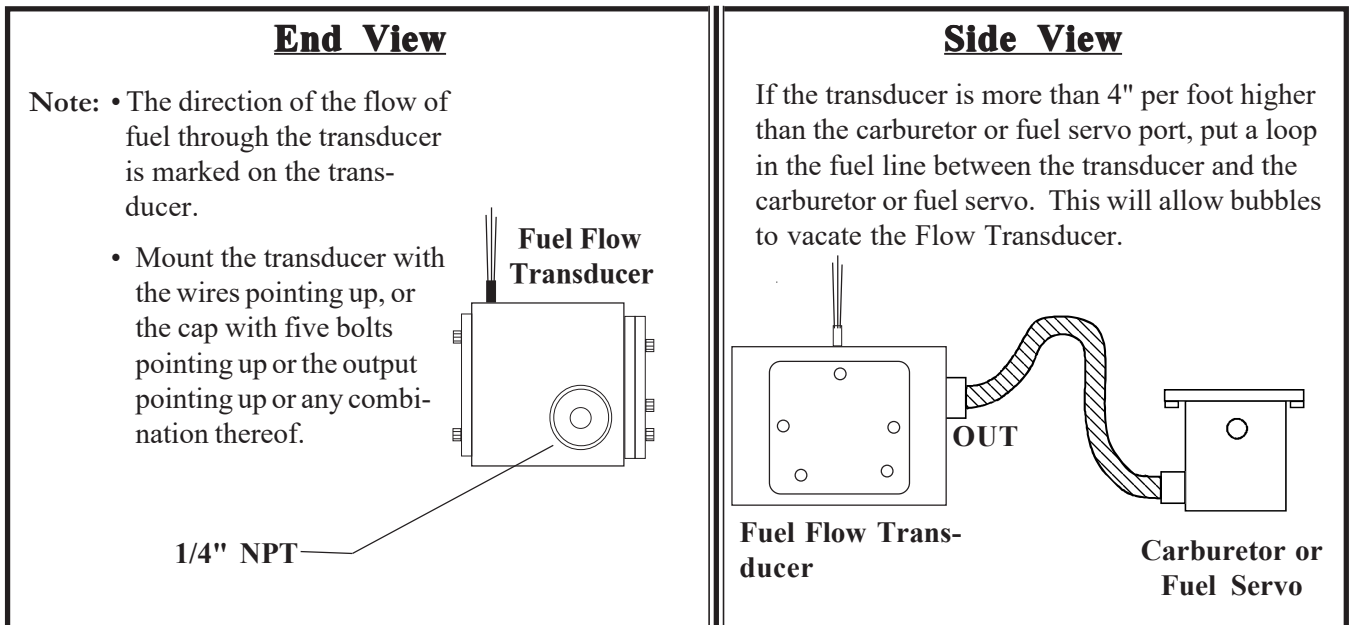

- B. Do not remove the yellow caps on the flow transducer until the fuel hoses are ready to be installed.
- C. The flow of fuel through the transducer must follow the direction marked on the transducer.
- D. The flow transducer must be mounted so the wires exiting the transducer are pointing up, or the cap with five bolts is pointing up, or the output port is pointing up, or any combination thereof.
- E. Before connecting any hoses, thoroughly clean them and insure they are free of any loose material. High air pressure may be used, **however, do not allow high air pressure to pass through the flow transducer.**
- F. When mounting a Fuel Flow Transducer, make provisions for the Fuel Pressure Transducer as necessary.

You may want to consider using some fittings and hoses shown below. Note: **DO NOT EXCEED a torque of 15 ft. lbs. or screw the fittings tighter than two full turns past hand tight, whichever happens first.**

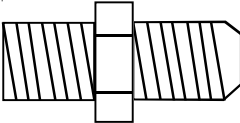
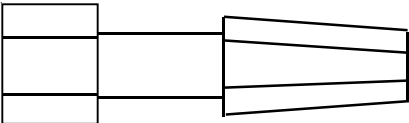
Fittings:	Hose Fittings:
 <p>1/4" NPT Flare</p>	 <p>Flare Hose</p>
<p>#4 Straight - AN816-4-4D #6 Straight - AN816-6D #8 Straight - AN816-7D</p> <p>#6 45' - MS20823-6D</p> <p>#4 90' - MS20822-4-4D #6 90' - MS20822-6D</p>	<p>Straight - MS24587-XX, Stratoflex 300-, Aeroquip 400-45' - MS27226-XX, Stratoflex 646- and 640, Aeroquip 980006 90' - MS27224-XX, Stratoflex 649- and 643, Aeroquip 980005</p> <p>NOTE: The Stratoflex teflon hose can be much more flexible and easier to route than most existing hoses. If you have a hard-to-fit installation, you might want to consider this hose.</p>

Important Note: Aluminum fittings should only be used when flex lines are mounted on the inlet and outlet ports of the flow transducer. Otherwise, steel, SS or brass fitting should be used.

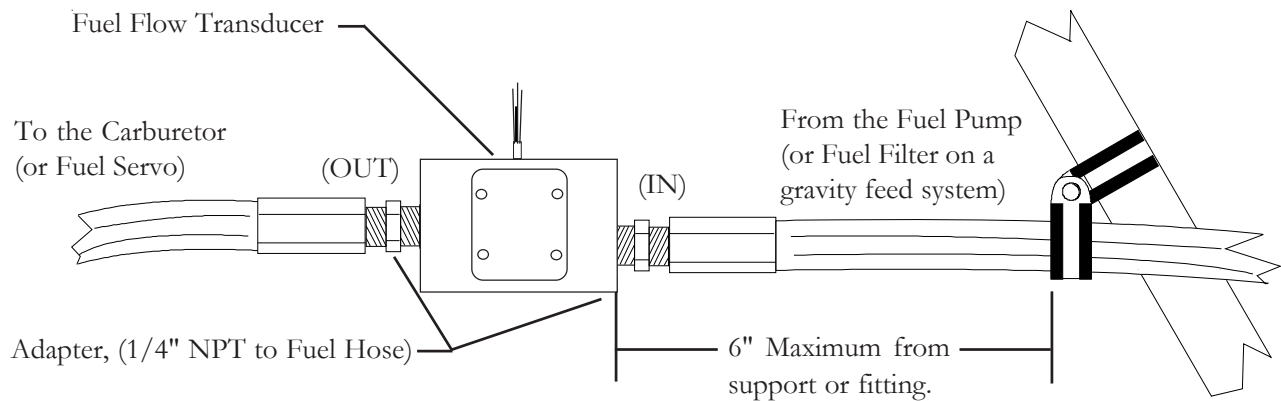

Mounting Procedure:

1. Find a convenient location within 6" of a hose support or fitting and away from any hot exhaust pipes to suspend the Fuel Flow Transducer. The hose support or fitting may be on the input or output line of the Flow Transducer and the support may be to an adjacent hose.
2. Remove the fuel hose which goes from the Fuel Pump (or the Fuel Filter on a gravity feed system) to the Carburetor (or Fuel Servo).
3. Purchase two new hoses: one to be used from the fuel pump (or the Fuel Filter) to the Fuel Flow Transducer and the other to be used from the Fuel Flow Transducer to the carburetor (or Fuel Servo). **There must be flexible hose in and out of the Transducer.** The hoses must meet TSO-C53a Type C or D FAA specifications. **The new hoses must be the same size as the current hoses in the aircraft.** Source of fittings and fabricated hoses are:

Aircraft Spruce
(877) 477-7823

4. Mount the Fuel Flow Transducer in the fuel line. **You must use the FT-90 (Gold Cube) Fuel Flow Transducer on a gravity feed system or for any engine over 350 H.P.** If the Transducer is mounted within 6" of an exhaust pipe, the Flow Transducer must be wrapped with Fire Sleeving.
5. **Read the Installation Instructions for important installation considerations.**

Drawn By:	R.R.	<i>Electronics International Inc.</i> Installation of a Fuel Flow Transducer suspended in the fuel line from the fuel pump to the carburetor or fuel servo. Note: <u>Not applicable</u> for a fuel-injected engine with a fuel return line (see D/N 0415941).					
Approved By:	R.R.						
Scale:	None						
Material:							
Next Assembly:							
P/N:		Date:	12/29/93	Rev:	E: 7/5/18	D/N:	1229932

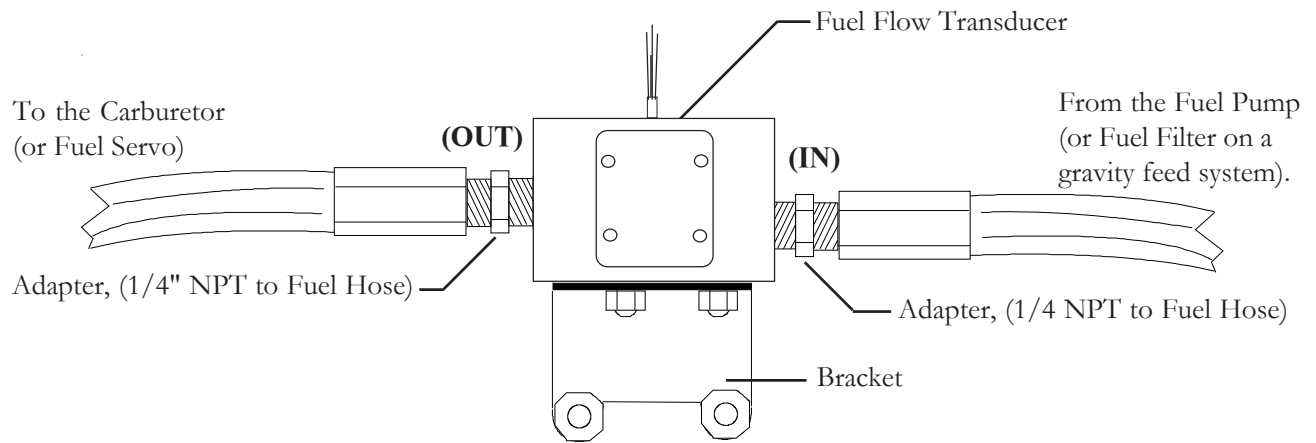

Mounting Procedure:

1. Find a convenient location on the firewall (away from any hot exhaust pipes) and mount a bracket for the Fuel Flow Transducer. Check both sides of the firewall for clearance before drilling any holes.
2. Mount the Fuel Flow Transducer onto the Bracket. **You must use the FT-90 (Gold Cube) Fuel Flow Transducer on a gravity feed system or for any engine over 350 H.P. If the Transducer is mounted within 6" of an exhaust pipe, the Flow Transducer must be wrapped with Fire Sleeving.**
3. Remove the fuel hose which goes from the Fuel Pump (or the Fuel Filter on a gravity feed system) to the Carburetor (or Fuel Servo).
4. Purchase two new hoses, one to be used from the fuel pump (or the Fuel Filter) to the Fuel Flow Transducer (making provisions for the fuel pressure transducer as necessary) and the other to be used from the Fuel Flow Transducer to the carburetor (or Fuel Servo). **There must be flexible hose in and out of the Transducer.** The hoses must meet TSO-C53a Type C or D FAA specifications. **The new hoses must be the same size as the current hoses in the aircraft.** Source of fittings and fabricated hoses are:

Aircraft Spruce
(877) 477-7823

5. **Read the Installation Instructions for important installation considerations.**

Drawn By: R.R.	<i>Electronics International Inc.</i>		
Approved By: R.R.	Installation of a Fuel Flow Transducer on the Firewall and in the fuel line <u>from the fuel pump to the carburetor or fuel servo.</u>		
Scale: None	Note: <u>Not applicable</u> for a fuel-injected engine with a fuel return line (see D/N 0415941).		
Material:			
Next Assembly:			
P/N:	Date: 12/29/93	Rev: E: 7/6/18	D/N: 1229931

To the Flow Divider

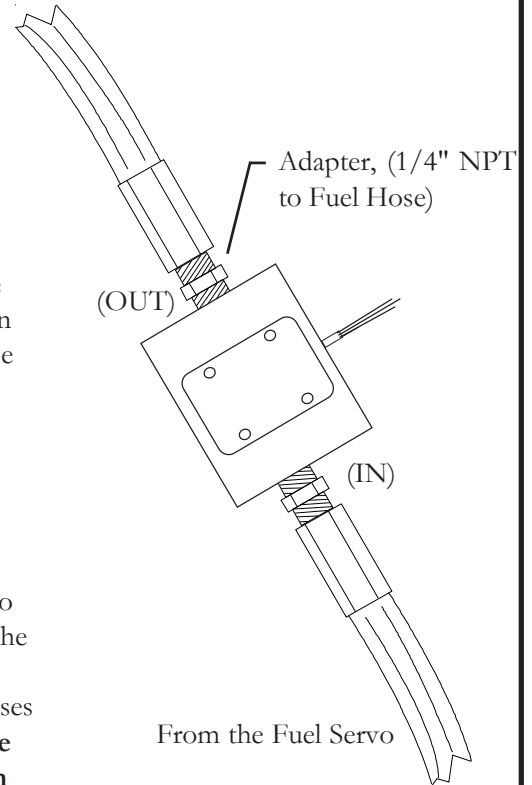

Mounting Procedure:

1. Find a convenient location between the Fuel Servo and Flow Divider and away from any hot exhaust pipes to suspend the Fuel Flow Transducer. The Transducer must be mounted within 6" of a hose support or fitting. The support or fitting may be on the input or output line of the Flow Transducer and the support may be to an adjacent hose.
2. Remove the fuel hose which goes from the Fuel Servo to the Flow Divider.
3. Purchase two new hoses: one to be used from the Fuel Servo to the Fuel Flow Transducer and the other to be used from the Fuel Flow Transducer to the Flow Divider. **There must be flexible hose in and out of the Fuel Transducer.** The hoses must meet TSO-C53a Type C or D FAA specifications. **The new hoses must be the same size as the current hoses in the aircraft.** Source of fittings and fabricated hoses are:

Aircraft Spruce
(877) 477-7823

4. Mount the Fuel Flow Transducer in the fuel line. **You must use the FT-90 (Gold Cube) Fuel Flow Transducer on any engine over 350 H.P.** If the Transducer is mounted within 6" of an exhaust pipe, the Flow Transducer must be wrapped with Fire Sleeving.
5. **Read the Installation Instructions for important installation considerations.**

Drawn By: R. R.	<i>Electronics International Inc.</i>		
Approved By: R.R.	Installation of the Fuel Flow Transducer suspended in the fuel line <u>between the Fuel Servo and the Flow Divider.</u>		
Scale: None	Note: <u>Only applicable</u> for installation on aircraft with a fuel return line from the Fuel Servo.		
Material:			
Next Assembly:			
P/N:	Date: 4/15/94	Rev: C: 7/6/18	D/N: 0415941

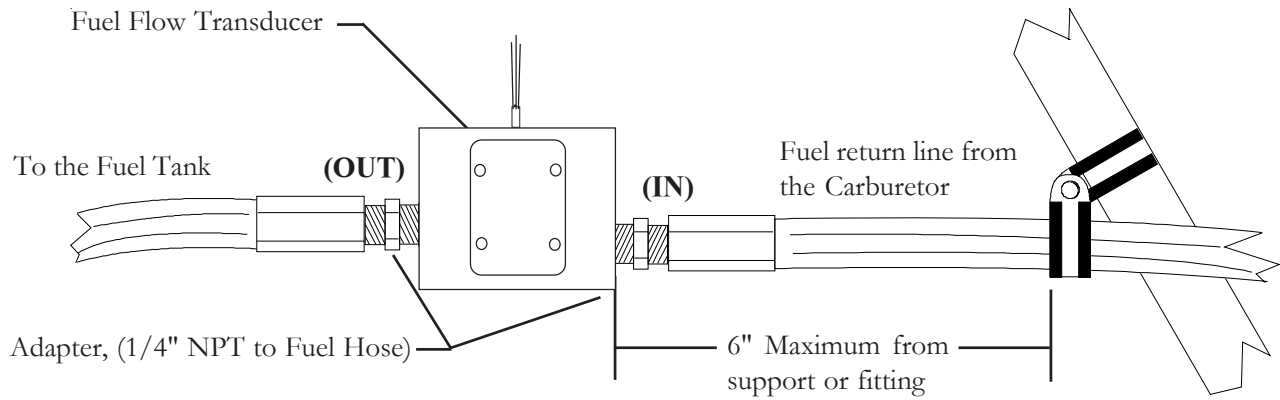

Mounting Procedure:

1. Find a convenient location within 6" of a hose support or fitting and away from any hot exhaust pipes to suspend the Fuel Flow Transducer. The hose support or fitting may be on the input or output line of the Flow Transducer and the support may be to an adjacent hose.
2. Remove the return fuel hose which goes from the Carburetor to the Fuel Tank.
3. Purchase two new hoses: one to be used from the Carburetor to the Fuel Flow Transducer and the other to be used from the Fuel Flow Transducer to the Fuel Tank. **There must be flexible hose in and out of the Transducer.** The hoses must meet TSO-C53a Type C or D FAA specifications. **The new hoses must be the same size as the current hose in the aircraft.** Source of fittings and fabricated hoses are:

Aircraft Spruce
(877) 477-7823

4. Mount the Fuel Flow Transducer in the fuel return line. **You must use the FT-90 (Gold Cube Fuel Flow Transducer on any engine over 350 H.P.)** If the Transducer is mounted within 6" of an exhaust pipe, the Flow Transducer must be wrapped with Fire Sleeving.
5. **Read the Installation Instructions for important installation considerations.**

Drawn By: R.R.	<i>Electronics International Inc.</i>		
Approved By: R.R.	Installation of a Fuel Flow Transducer suspended in the <u>fuel return line</u> from the carburetor to the fuel tank.		
Scale: None	Note: <u>Only applicable</u> for installation on aircraft with a fuel return line from the <u>Carburetor</u> .		
Material:			
Next Assembly:			
P/N:	Date: 10/15/94	Rev: B: 7/6/18	D/N: 1015941

2.14 Install the EI P-300C Fuel Level Probes (OEM or Experimental Only):

Install the P-300C (Capacitive) Fuel Level Probes in accordance with the aircraft manufacturer's instructions.

2.15 Install the EI P-300M Magnetic Fuel Level Sender:

The MVP-50 system can interface with an aircraft's existing Resistive Fuel Sensors via the RFLM-4 or these resistive fuel level sensors can be replaced with the P-300M (Magnetic Float) Fuel Level Sender. The signal produced by the P-300M Sender is a linear voltage output designed to work with the MVP-50 system.

The P-300M's float arm and travel must match the aircraft's existing sender's arm and travel. Due to the lack of information from aircraft manufacturers, the existing sender will need to be removed from the aircraft and sent to Electronics International. In this way the P-300M's float arm and travel can be matched with the aircraft's existing sender. Contact Electronics International for further information.

The P-300M has the same bolt pattern as resistive fuel senders. The P-300M requires three wires to interface to the EDC (resistive senders only use one wire).

Note: Calibrating the MVP-50P to a fuel tank can compensate for nonlinearity in the tank's shape and nonlinearity in the resistive fuel level sensor. The MVP cannot correct for inconsistent or non-repeatable signals from resistive fuel level senders. Unfortunately, many older resistive fuel level senders (and in some cases, newer resistive senders) exhibit some of the following problems:

- Variation in the wiper-to-element resistance (CRV).
- Stick slip problems with bearings and wiper-to-element contact.
- Windup causing jumps in readings.
- Weak wiper tension.
- Loose or worn bearings, causing fluctuations in tension and resistance.
- Worn out wiper.
- Corroded wiper.
- Corroded or worn element.
- Build up of varnish on the wiper and element.
- Water logged floats.

If you find inconsistent or inaccurate fuel level readings (due to a defective resistive fuel level sender), you must have the sender replaced. Inaccurate readings can lead to a dangerous situation. The MVP-50P depends on the fuel level sender for accurate fuel level information. Read the "Important Notice" in the MVP Operating Instructions.

The P-300M is a float type fuel level sender that uses a magnet and pickup device to detect the float position and produce the signal for the MVP-50 system. The P-300M has no wiper or resistive element and there is no tension on the bearing surfaces. It is not subject to the many problems associated with resistive type senders. The P-300M has nothing to wear out or affect inaccurate fuel level readings. Also, the P-300M does not require electricity to flow through an element and wiper saturated in fuel, as is the case with resistive senders.

2.16 Install the Resistive Fuel Level Module (RFLM-4-X):

The RFLM-4 is a Resistive Fuel Level Module that provides pull-up resistors for 4 resistive fuel level sensors. This module is required to interface an EDC Resistive Fuel Level Input to a Resistive Fuel Sensor. The RFLM-4 is to be connected to an EDC.

Warning: DO NOT connect an RFLM-4 to the output of an existing aircraft's Capacitive System, damage to the system may occur. The small output voltage of an existing capacitive system currently drives a fuel level gauge. This output wire should be routed to one of the resistive fuel level inputs on the EDC with NO connection to an RFLM unit.

There are two RFLM-4 modules available. The RFLM-4-12V operates on a 12-volt electrical system and the RFLM-4-24V operates on a 24-volt electrical system. The appropriate model must be used.

Mount the RFLM-4-X under the instrument panel or in the equipment bay. Use the holes in the bottom plate to mount the unit. Only two mounting holes are required.

Note: For each Fuel Level Channel on the EDC you can use either the Resistive Input or the Capacitive Input, but not both.

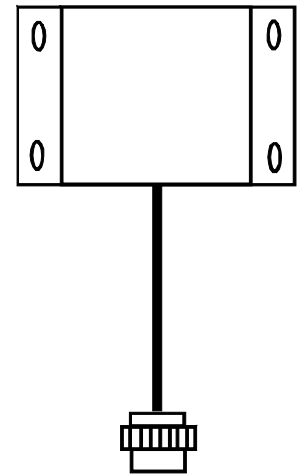

To EDC Resistive Fuel Level Inputs (Bottom Connector) and the Fuel Level Sensor.

2.17 Install the Intensity Control Pot (Optional):

The display intensity of both of the the MVPs may be controlled internally with an electric eye or externally with a single Intensity Control Pot (CP-1A). The selection is pilot programmable. If the intensity is to be controlled externally, an CP-1A will need to be installed in the aircraft instrument panel.

- A. Locate the Intensity Control Pot in the CP-1A packet. Find an appropriate mounting location on the aircraft instrument panel for the Control Pot. The Pot will require a 2" clearance behind the aircraft instrument panel.
- B. Mark the aircraft instrument panel and drill a 1/4" hole for the Pot.
- C. Mount the Pot from behind the aircraft instrument panel and install the knob.

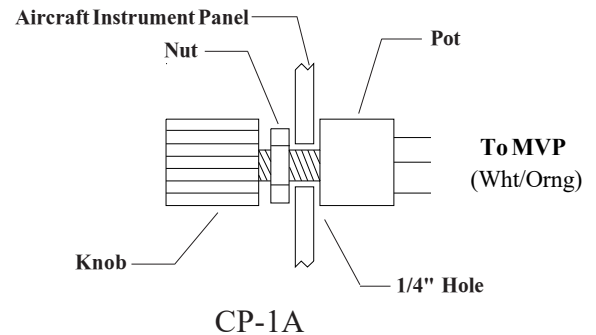

2.18 Install the Warning (red) and Caution (yellow) Lights:

The Warning and Caution Lights do not have to be installed unless one of the MVP displays are installed more than 8" from the pilot's visual centerline. Each MVP will have a Red & Yellow light set, each MVP will control one set of lights.

A. Locate the two Red (AL-1R) and two Yellow (AL-1Y) lights in the kit. Find an appropriate mounting location within 8" of the pilot's visual centerline. The lights will require 3/4" clearance behind the aircraft instrument panel.

B. Mark the aircraft instrument panel and drill a 5/16" hole for each light. Install the Red Warning Light and the Yellow Caution Light from behind the aircraft instrument panel.

Note: If the MVP Master Warning and Caution Outputs are connected to other lights or devices, the current must be limited to 0.1 amps. The outputs pull to ground when active. These lights may also be connected to the CP-1A which can assist in controlling the light intensity.

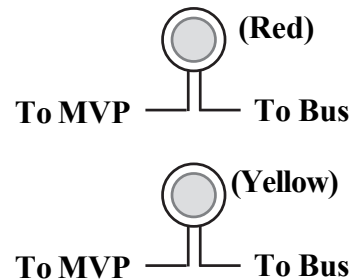

2.19 Install the USB-6A (Optional):

The USB-6A is an FAA PMA'd standalone unit that provides a USB port. The USB-6A may be installed using the instructions provided with the USB-6A unit.

2.20 Install any Additional Modules (Optional):

If any additional modules are provided with the system, install them at this time using the instructions provided with the modules.

2.21 Installing the EDC-33Ps:

The EDC measures 4.5" long by 3.5" wide by 2.2" high. Each EDC-33P (Engine Data Converter, "EDC") converts the engine and aircraft system signals into serial data. The data from the Left EDC (monitoring the left engine) is transmitted to the Left MVP display via two wires (RS422) and the Right EDC (monitoring the right engine) is transmitted to the Right MVP display via two wires (RS422).

Mount the Left and Right EDCs behind the firewall of the appropriate engine (in the nacelle) or in the wing or at the wing root. The EDCs should NOT be installed in the engine compartment. Use the holes in the bottom plate of the EDC to mount the unit. Be sure you have enough room to connect the three D-sub connector wire harnesses to the EDC. The EDC reduces the wire bundle to the instrument panel by over 200 wires. There are three 37-pin D-sub connectors that interface the EDC to the various probes, transducers and modules.



EDC-33P

Install the EDC Wire Harnesses and Route Wires

- | | | |
|-------------|------------------------------------------------------------------------------------------------------------------------|-----------|
| 3.1 | Attach the three EDC 37-pin Wire Harnesses to each EDC:----- | 37 |
| 3.2 | Connect the Left and Right EDC Harnesses to the Temperature Probes: ---- | 37 |
| 3.3 | Connect the Left and Right EDC Harnesses to the Pressure Transducers: -- | 37 |
| 3.4 | Connect the Left and Right EDC Harnesses to the Shunts: ----- | 37 |
| 3.5 | Connect the Left and Right EDC Harnesses to the Fuel Flow Transducer: -- | 38 |
| 3.6 | Connect the Left and Right EDC Harness to the Existing Capacitive Fuel Level Systems: ----- | 38 |
| 3.7 | Connect the RFLM-4-x Harness to the Left and Right EDC Connector and to the Resistive Fuel Level Sensors: ----- | 39 |
| 3.8 | Connect the EDC Harness to the EI P-300C Capacitive Fuel Level Probes: ----- | 39 |
| 3.9 | Connect the EDC Harness to the EI P-300M Magnetic Fuel Level Senders: ----- | 40 |
| 3.10 | Connect the Left and Right EDC Harness (Volts Measurement Pin) to the Bus: ----- | 40 |
| 3.11 | Connect the Left and Right EDC Harnesses to the RPM Signals: ----- | 40 |
| 3.12 | Set up the Left and Right EDCs for a 4 or 6-Cylinder Engine: ----- | 40 |
| 3.13 | Connect the Left and Right EDC Harness to the VI-221's (Voltage Interface Units): ----- | 40 |
| 3.14 | Connect the EDC Harnesses to Power and Ground: ----- | 41 |
| 3.15 | Route the EDC RS422 Wires to the MVP Connector: ----- | 41 |

Blank Page

3.1 Attach the three appropriate EDC 37-pin Wire Harnesses to each EDC:

Secure the connectors using the supplied mounting screws.

3.2 Connect the Left and Right EDC Harnesses to the Temperature Probes:

Route each of the temperature cables in the EDC harness to the appropriate temperature probe. Cut the wires to length, install the appropriate connectors (see the “Working with Connectors” section of the manual for more information) and connect to the temperature probe. When connecting to a temperature probe, leave some slack in the cable exiting the probe to prevent damage to the probe over time.

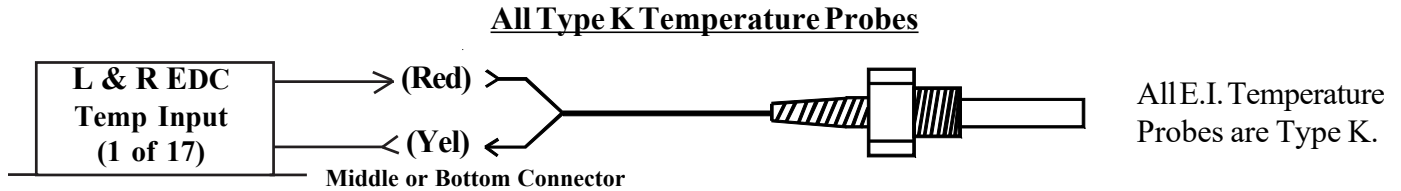

3.3 Connect the Left and Right EDC Harnesses to the Pressure Transducers:

Route each of the pressure cables in the EDC harness to the appropriate pressure transducers. Cut the wires to length, install the appropriate connectors (see the “Working with Connectors” section of this manual for more information) and connect to the pressure transducer. When connecting to a pressure transducer, leave some slack in the cable exiting the transducer to prevent future damage to the transducer.

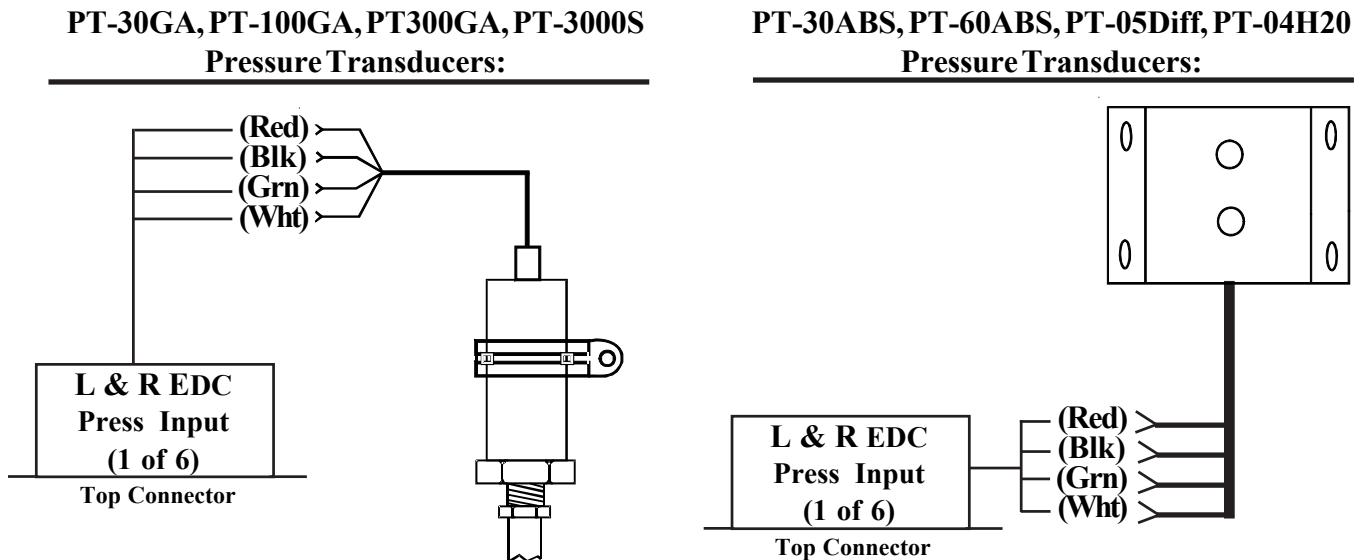

3.4 Connect the Left and Right EDC Harnesses to the Shunts:

Route the EDC Amps wires to the Shunt. The way the Shunt is installed in the aircraft determines which lug will be used as "+" (see “Installing the Shunt” in the previous section of this manual). The EDC +Amp Input wire (orange) should be connected to the small lug on the "+" side of the Shunt. The EDC -Amp Input wire (brown) should be connected to the small lug on the "-" side of the Shunt.

3.5 Connect the Left and Right EDC Harnesses to the Fuel Flow Transducer:

Route the fuel flow cable in the EDC harness to the Fuel Flow Transducer. Cut the wires to length, install the appropriate connectors (see the “Working with Connectors” section of this manual for more information) and connect to the fuel flow transducer. When connecting to the Fuel Flow Transducer, leave some slack in the cable exiting the transducer to prevent future damage to the transducer.

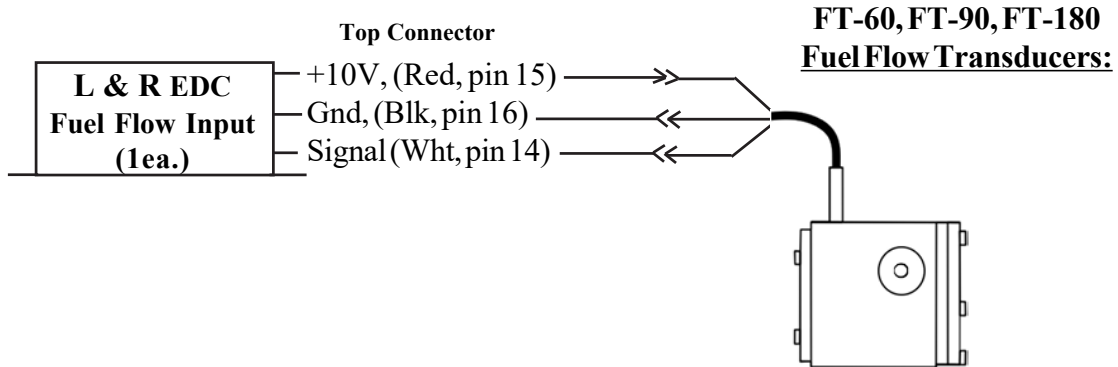

3.6 Connect the Left or Right EDC Harness to the Existing Capacitive Fuel Level System:

The output signal of a capacitive fuel level system (on a certified aircraft) will have a wire connected from the capacitive system to the fuel level gauge. The signal on this wire will be 0 to approx 150mV DC. The other side of the gauge will be grounded. Re-route the signal wire (currently connected to the fuel level gauge) to one of the resistive inputs on the bottom connector of the EDC. DO NOT connect an RFLM unit into this system, damage to the system may occur. The current fuel level gauge must be removed from the system.

A 332-ohm resistor should be connected from the signal wire to ground. For a MVP-50 STC'd system, this resistor is integrated into the wire harness supplied with the system.

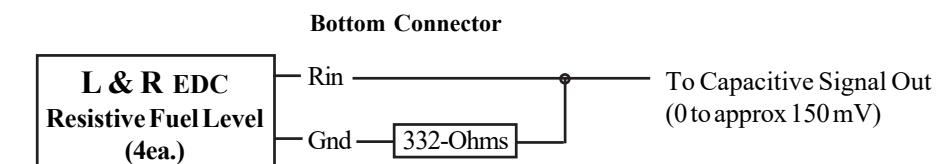

3.7 Connect the RFLM-4-x Harness to the either the Left or Right EDC Connector and to the Resistive Fuel Level Sensors:

DO NOT connect the RFLM into a capacitive system, damage may occur. Route the appropriate resistive fuel level input wires (for the number of tanks to be monitored) in the RFLM-4-x harness to the EDC Bottom Connector. Plug the wires into the appropriate resistive fuel level channels. The excessive wire can be cut and spliced, bundled and tie wrapped up or cut to length and new D-Sub pin installed (see the “Working with Connectors” section of this manual for more information). Route and connect the corresponding wires in the RFLM-4-x wire harness to the appropriate fuel tank sensors. Route the red wire (in pin 1 of the RFLM-4-x connector) to the aircraft bus via the MVP/EDC 5 to 10-amp circuit breaker.

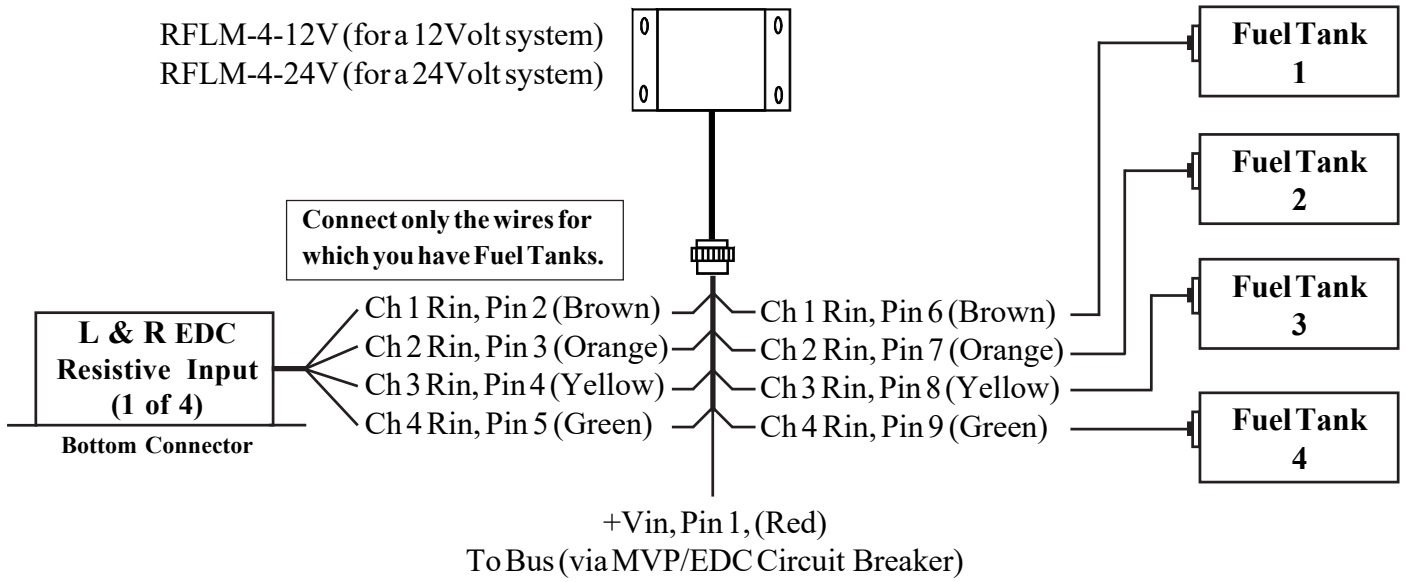

3.8 Connect the EDC Harness to the EI P-300C Capacitive Fuel Level Probes:

Route the appropriate capacitive fuel level wires (for the number of tanks to be monitored) in the EDC harnesses to the capacitive fuel level probes. Cut the wires to length, install the appropriate connectors (see the “Working with Connectors” section of this manual for more information) and connect to the capacitive fuel level probe.

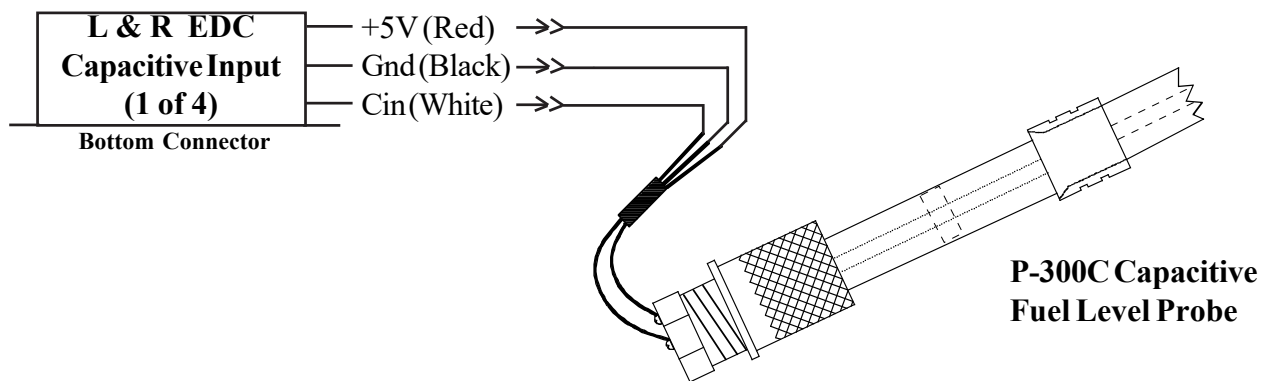

Note: The capacitive fuel level channels are shared with the resistive channels. A single capacitive and resistive channel cannot be used simultaneously.

3.9 Connect the EDC Harness to the EI P-300M Magnetic Fuel Level Senders:

Route the appropriate fuel level wires (for the number of tanks to be monitored) in the EDC harnesses to the P-300M magnetic fuel level senders. Cut the wires to length, install the appropriate connectors (see the “Working with Connectors” section of this manual for more information) and connect to the P-300M fuel level sender.

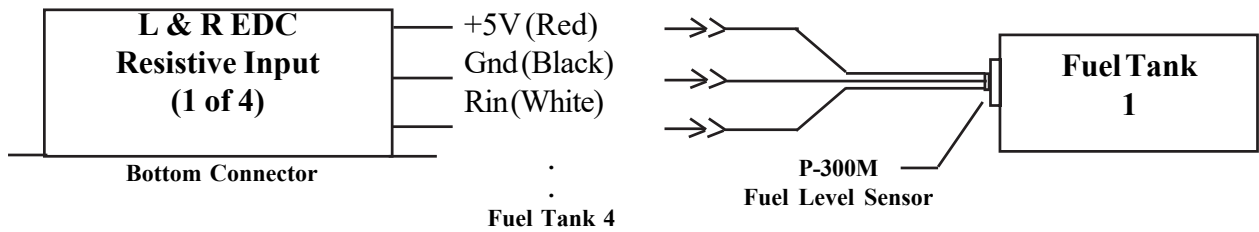

3.10 Connect the Cabin EDC Harness (Volts Measurement Pin) to the Bus:

Pin 35 of the cabin EDC top connector monitors bus voltage. Connect this pin to the bus to be monitored.

3.11 Connect the Left and Right EDC Harnesses to the RPM Signals:

If the EDC RPM Ch 1 and Ch 2 Inputs are to be connected to a Magneto, Ignition Coil or CDI Ignition System, connect the Ring Terminal Isolators (found in the RPM Isolator packet) to the P-leads on the back of the Mag Switch. Connect the EDC RPM Ch 1 and Ch 2 wires (White/Brown and White/Orange) to the RPM Isolators.

If the EDC RPM Ch 1 and Ch 2 Inputs are to be connected to an electronic ignition system, connect the EDC RPM Ch 1 and Ch 2 wires (White/Brown and White/Orange) directly to the electronic ignition system RPM output (do not use any isolators). Without isolators the EDC RPM Ch 1 and Ch 2 Inputs have a 3-volt trigger level and will accommodate 0 to 5-volt, 0 to 12-volt or 0 to 24-volt signals. If only one RPM signal is available, connect only one of the EDC RPM channels.

WARNING: Connecting an EDC RPM input directly to a magneto without an Isolator will damage the EDC. Be sure there is an Isolator in each RPM input lead connected to a magneto, ignition coil or CDI ignition.

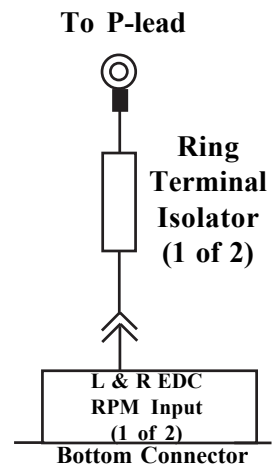

3.12 Set up the Left and Right EDCs for a 4 or 6-Cylinder Engine:

If the EDC-33P is to be used on a 6-cylinder engine, strap pin 28 to Pin 27 on the EDC Bottom Connector. Leave these pins open for a 4-cylinder engine. This strap may already be installed or can be found in the kit.

3.13 Connect the Left and Right EDC Harness to the VI-221's (Voltage Interface Units):

Route the appropriate EDC wire to the VI-221's that were used to interface the Gear Position Lights, Unsafe Light, Flap Position, Trim Position and/or any indicator to the EDC.

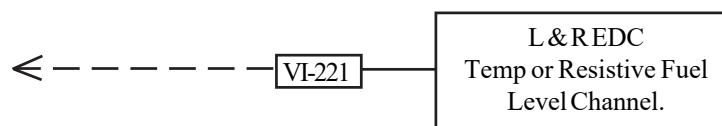

3.14 Connect the EDC Harnesses to Power and Ground:

Route the power wire (Top Connector, pin 37, Red Wire) to the MVP/EDC 5-amp Circuit Breaker. Route the ground wire (Top Connector, pin 19, Black Wire) to the aircraft ground. One 5 to 10 Amp Circuit Breaker should be use for the Left MVP, Left EDC, Cabin EDC and all Modules. Another 5 to 10 Amp Circuit Breaker should be used for the Right MVP and Right EDC.

WARNING: The power wire is RED and is connected to pin 37 on the EDC Top Connector. If aircraft power is connected to any pin on the EDC other than pin 37, damage to the EDC and any connected transducers may occur. Insure power is provided on pin 37 of the EDC Top Connector before attaching the connector.

3.15 Route the EDC RS422 Wires to the MVP Connector:

The Left EDC will transmit infomraiton to the Left MVP-50P display, the Right EDC will transmit information to the Right MVP-50P display.

1. Connect the Left EDC RS422 Output (pins 36 and 18) to the EDC input on the Left MVP (pins 12 and 13, see the Left MVP Wiring Diagram and the Left EDC Work Sheet, Top Connector).
2. Connect the Right EDC RS422 Output (pins 36 and 18) to the EDC input on the Right MVP (pins 12 and 13, see the Right MVP Wiring Diagram and the Right EDC Work Sheet, Top Connector).

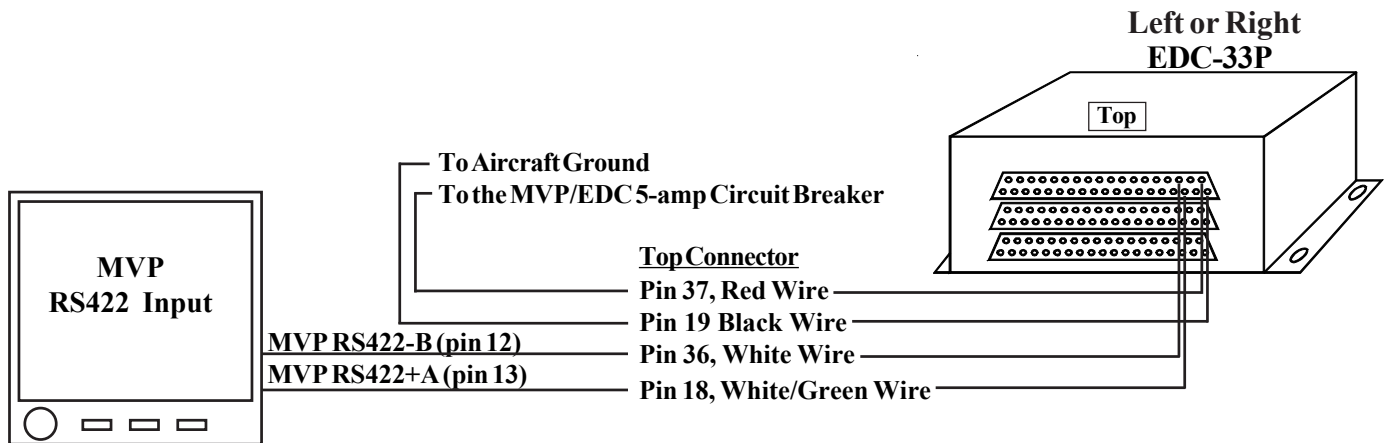

Blank Page

Install the MVP Wire Harnesses and Route Wires

- 4.1 Attach the MVP 25-pin D-sub Connector to the MVPs: ----- 45
- 4.2 Connect the EDC RS422 Wires to the MVP RS422 Wires: ----- 45
- 4.3 Connect the MVP Harnesses to the Master Warning and Caution Lights: --- 45
- 4.4 Connect the MVP Harnesses to the External Intensity Control Pot (CP-1): -- 45
- 4.5 Connect the MVP Harnesses to the Moving Map Data Out from the GPS: -- 46
- 4.6 Connect the Left MVP Harness to the Fuel Data Input on the GPS: ----- 46
- 4.7 Connect the MVP "Transmit Lockout Input" Pin to the Transmit Key: ----- 46
- 4.7 Connect the MVP Harnesses to Power and Ground: ----- 46

Blank Page

4.1 Attach the MVP 25-pin D-sub Connectors to the MVPs:

Secure the connector using the supplied mounting screws.

4.2 Connect the EDC RS422 Wires to the MVP RS422 Wires:

Route the EDC RS422 wires to the back of the appropriate MVP Display, cut the wires to length and splice them to the appropriate MVP RS422 wires.

4.3 Connect the MVP Harnesses to the Master Warning and Caution Lights:

If the Warning and Caution Lights are installed, route the appropriate MVP Master Warning Out wire (White/Yellow, Pin 16) to the appropriate Master Warning (Red) Light (AL-1R) White/Yellow wire, cut the wires to length, install the appropriate connectors (see the “Working with Connectors” section of this manual for more information) and connect to the AL-1R.

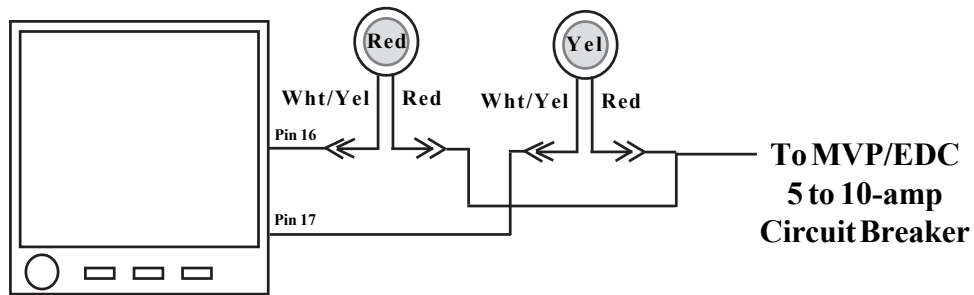

Route the appropriate MVP Master Caution Out wire (White/Yellow, Pin 17) to the appropriate Master Caution (Yellow) Light (AL-1Y) White/Yellow wire, cut the wires to length, install the appropriate connectors and connect to the AL-1Y.

4.4 Connect the MVP Harnesses to the External Intensity Control Pot (CP-1A):

If the MVP display intensity is to be controlled externally, route the MVP Back Light Control In wires (orange) to the CP-1A, cut the wires to length, install the appropriate connectors (see the “Working with Connectors” section of this manual for more information) and connect to the CP-1A. Install the ground and power wires to the CP-1A as shown in the paperwork supplied with the control pot.

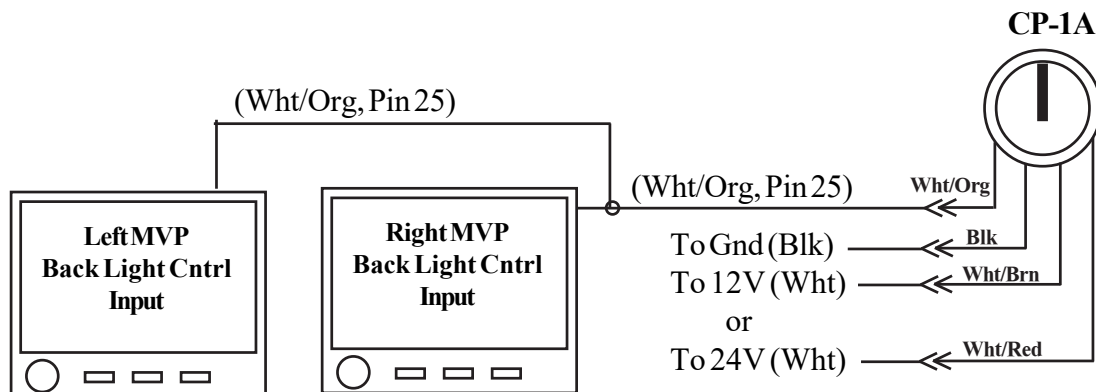

4.5 Connect the Left and Right MVP Harnesses to the Moving Map Data Out from the GPS:

If the MVP is to provide fuel data to the current way point, route the Left and Right MVP "Moving Map Data In" wire (green wire in a 4 wire cable) to the Moving Map Data Output Port on the GPS. Cut the wire to length, install the appropriate connector and connect to the GPS port.

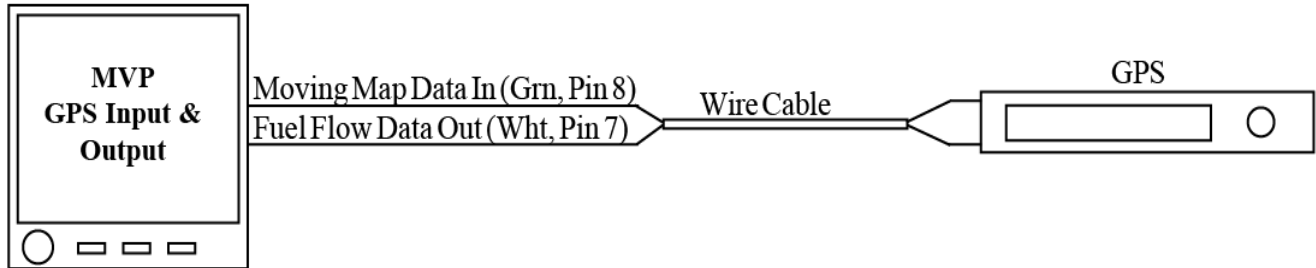

4.6 Connect the Left MVP Harness to the Fuel Data Input on the GPS:

If the GPS is capable of displaying fuel data and this feature is to be used, route the Left MVP "Fuel Data Out" wire (white wire in a 4-wire cable) to the Fuel Data Input Port on the GPS. Cut the wire to length, install the appropriate connector and connect to the GPS port.

4.7 Connect the MVP "Transmit Lockout Input" Pin to the Transmit Key:

Pulling the MVP Transmit Lockout Input Pin to ground freezes the displayed values for the various functions. This eliminates jumpy readings during transmit. In most (if not all) cases the MVP "Transmit Lockout Input" does not need to be connected. If transmit lockout is required, attach the appropriate pin (see the "Working with Connectors" section of this manual for more information) to a 20 ga. wire. Install the wire into pin 3 of the MVP connector. Route and attach this wire to the transmit key.

4.8 Connect the MVP Harnesses to Power and Ground:

Route the power wire (red) to the main bus via a 5 to 10-amp Circuit Breaker. One 5 to 10-amp Circuit Breaker should be use for the Left MVP, Left EDC, Cabin EDC and all Modules. Another 5 to 10-amp Circuit Breaker should be used for the Right MVP and Right EDC. Route the ground wire (black) to the aircraft ground.

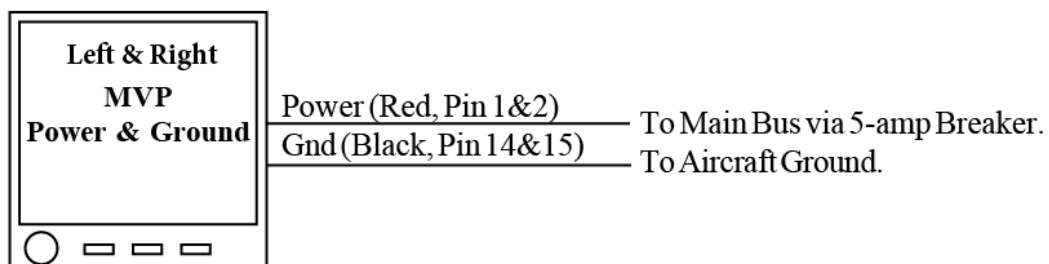

WARNING: The power wire is RED and is connected to pin 1 and 2 on the MVP. If aircraft power is connected to any pin on the MVP other than pin 1 and 2, damage to the MVP and any connected hardware may occur. Insure power is provided on pin 1 and 2 of the MVP before attaching the connector.

Mandatory System Setup and Checkout

5.1 Power-On Checkout: ----- 49

5.2 Perform all Steps listed in the "MVP-50P Setup Checklist": ----- 49

5.3 Ground Run Checkout: ----- 49

5.4 First Flight Checkout: ----- 50

5.5 Read the "Warranty/Agreement" and the "Important Notice": ----- 50

Blank Page

5.1 Power-On Checkout:

Turn the aircraft master switch on. Each MVP will power up and perform a system test. After approximately 14 seconds each MVP will display the "Main Engine" screen with an Add Fuel Message. Press any button on each unit to continue. If you have a problem with any of the following steps, see the Troubleshooting section of this manual.

- A. Check the RPM for a reading of 000.
- B. Check the M.P. for the following reading:
Current BARO (from ATIS) less 0.1"Hg for every 100 feet elevation above sea level.
- C. Check Fuel Flow for a reading of 00.0.
- D. Check Oil Pressure for a reading of 00.
- E. Check Oil Temp to read near ambient temperature.
- F. Check Volts for proper reading.
- G. Check Amps for proper reading.
- H. Check all EGT's to read near ambient temperature.
- I. Check all CHT's to read near ambient temperature.
- J. Check OAT to read ambient temperature.
- K. Check all Annunciators for proper operation.
- L. Check gear indications on the System screen to operate properly.
- M. Check all other functions on the Main and System screen to operate properly.
- N. Check aircraft instruments for any EMI interference.

Note: Fuel Level, Trim, Flaps and Pressure Altitude may not read properly until they have been calibrated.

5.2 Perform all Steps listed in the "MVP-50P Setup Checklist":

A Setup Checklist is provided. Each step listed in this checklist must be completed for each system before continuing with this installation.

5.3 Ground Run Checkout:

Start the aircraft engine. Check that the values for each function displayed on each MVP are proper for "engine on" operation. Any problem with a specific function will be associated with a probe, cable or interconnect cable between the probe and the EDC for that function. If you have a problem with any of the following steps, see the Troubleshooting section of this manual.

- A. Check the RPM.
- B. Check the M.P.
- C. Check Fuel Flow.
- D. Check Oil Pressure.
- E. Check Oil Temperature.
- F. Check Fuel Level for each Tank.
- G. Check Volts.
- H. Check Amps.
- I. Check all EGTs.
- J. Check all CHTs.
- K. Check OAT.
- L. Check all Annunciators.
- M. Check gear indications.
- N. Check Flap and Trim indications.
- O. Check all other functions on the Main and System screen.

Turn the engines off. Inspect the entire system to be certain there is no interference with controls. Also, check for loose fittings, proper connections, clamps, probes, and inspect for leaks, chafing, obstructions, heat damage and anything that may cause unsafe flight. **Check that all fittings are tight.** Loose fitting can cause engine and/or aircraft damage and possibly personal injury.

5.4 First Flight Checkout:

Prepare the aircraft for flight. Fly the aircraft in the pattern. Check for proper operation of each function displayed on each MVP. Land the aircraft and perform the following checks as soon as possible:

- A. Check all fittings, hoses and transducers for leaks.
- B. Check all fittings, hoses, wires, system components and hardware to be secure and not chaffing.
- C. Check for interference to any controls.
- D. Check for any unsafe condition.

Do not release the aircraft for normal operation until all steps in this document have been performed and the aircraft is safe to fly.

5.5 Read the "Warranty/Agreement" and the "Important Notice":

Require the pilot to read the "Warranty/Agreement" and the "Important Notice" located in the front of the "Operating Instructions" before releasing the aircraft for flight.