

Volts / Amps

(Primary Instruments)

(VA-1A, VA-1A-XX & RSVA-3)

Operating and Installation Instructions

OI 041032 and II 040934

4/9/83

Rev. C: 2/24/92 ***

S/N: ~74000 and up.

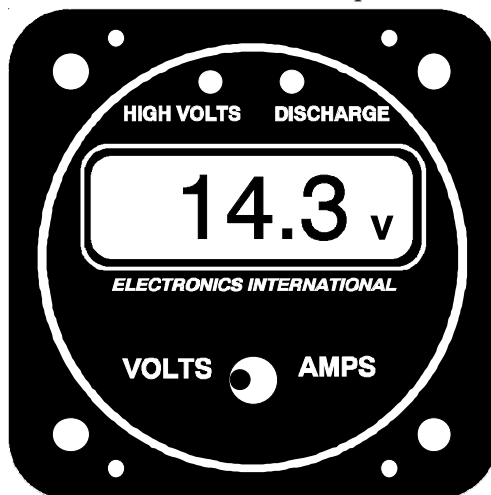

You must read this manual before installing or operating the instrument. This manual contains warranty and other information that may affect your decision to install this product and/or the safety of your aircraft.

Model: _____

S/N: _____



Electronics International Inc. ®

63296 Powell Butte Hwy • Bend, OR 97701 • (541) 318-6060 • Buy-EI.com 

Important Notice

******* MUST READ *******

If you think it is not important to read this manual, you're wrong! This manual contains important installation information that may affect the safety of your aircraft, delay your installation or affect the operation of your instrument. You Must read this manual prior to installing your instrument. Any deviation from these installation instructions is the sole responsibility of the installer/pilot and may render the STC invalid.

Read the Warranty / Agreement. There is information in the Warranty / Agreement that may alter your decision to install this product. **If you do not accept the terms of the Warranty / Agreement, do not install this product.** This product may be returned for a refund. Contact Electronics International inc. for details.

Check that the instrument make and model marked on the side of the instrument and on the invoice are correct before starting the installation. The VA-1A is an internal shunt unit and the VA-1A-XX is an external shunt unit ("XX" = your aircraft shunt value in amps).

It is possible for any instrument to fail thereby displaying inaccurate high, low or jumpy readings. Therefore, you must be able to recognize an instrument failure and you must be proficient in operating your aircraft safely in spite of an instrument failure. If you do not have this knowledge, contact the FAA or a local flight instructor for training.

The ability for this product to detect a problem is directly related to the pilots interpretation and observation skills.

The pilot **must** understand the operation of this product before flying the aircraft. Do not allow anyone to operate the aircraft that does not know the operation of this product. Keep the Operating Manual in the aircraft at all times.

Contents

WARRANTY	2
VA-1A, VA-1A-XX Operating Instructions	3
Features	3
VA-1A Installed in the Battery Lead	4
VA-1A Installed in the Alternator Lead.....	6
VA-1A, VA-1A-XX Installation Instructions	8
General Information.....	8
Installation	9
1. Important Information and Initial Check Out	9
2. Instrument Set Up	9
3. Determine how the VA Unit will be installed in your aircraft's electrical system	9
4. Install the External Shunt (External Shunt Unit Only, VA-1A-XX)	12
5. Route the Circular Connectors	12
6. Route the Power and Ground Wires	12
7. Route the Backlight Wires	12
8. Route the Shunt Wires (External Shunt Unit Only, VA-1A-XX).....	13
9. Connect the Large Shunt Wires (Internal Shunt Unit Only, VA-1A)	13
10. Install the Instrument in the Panel.....	13
11. Connect the Circular Connector to the Instrument	13
12. Ground Tes:	13
Troubleshooting	14
VA-1A (Internal Shunt Unit) Wiring Diagram	16
VA-1A-XX (External Shunt Unit) Wiring Diagram	17
VA-1A and VA-1A-XX Circular Connector	18
RSVA-3 Installation Instructions.....	19
1. Install the External Shunt	19
2. Install the VA-1A-XX Instrument	19
3. Route the Shunt Wires	19
4. Route the Instrument Wires to the RSVA-3.....	19
5. Install the RSVA-3 in the Panel	20
6. Ground Test.....	20
RSVA-3 Wiring Diagram	21
RSVA-3 Circular Connector	22
Specifications and Operating Features	23
STC Information.....	See Back Pages

Warranty / Agreement

Electronics International Inc. warrants this instrument and system components to be free from defects in materials and workmanship for a period of one year from the user invoice date. Electronics International Inc. will repair or replace any item under the terms of this Warranty provided the item is returned to the factory prepaid.

1. This Warranty shall not apply to any product that has been repaired or altered by any person other than Electronics International Inc., or that has been subjected to misuse, accident, incorrect wiring, negligence, improper or unprofessional assembly or improper installation by any person. **This warranty does not cover any reimbursement for any person's time for installation, removal, assembly or repair.** Electronics International retains the right to determine the reason or cause for warranty repair.
2. This warranty does not extend to any machine, vehicle, boat, aircraft or any other device to which the Electronics International Inc. product may be connected, attached, interconnected or used in conjunction with in any way.
3. The obligation assumed by Electronics International Inc. under this warranty is limited to repair, replacement or refund of the product, at the sole discretion of Electronics International Inc.
4. Electronics International Inc. is not liable for expenses incurred by the customer or installer due to factory updates, modifications, improvements, upgrades, changes, or any other alterations to the product that may affect the form, fit, function or operation of the product.
5. Personal injury or property damage do to misinterpretation or lack of understanding this product is solely the pilots responsibility. The pilot **must** understand the operation of this product before flying the aircraft. Do not allow anyone to operate the aircraft that does not know the operation of this product. Keep the Operating Manual in the aircraft at all times.
6. E. I. Inc. is not responsible for shipping charges or damages incurred under this Warranty.
7. No representative is authorized to assume any other liability for Electronics International Inc. in connection with the sale of Electronics International Inc. products.
8. **If you do not agree to and accept the terms of this warranty, you may return the product for a refund.**

This Warranty is made only to the original user. **THIS WARRANTY IS IN LIEU OF ALL OTHER WARRANTIES OR OBLIGATIONS: EXPRESS OR IMPLIED. MANUFACTURER EXPRESSLY DISCLAIMS ALL IMPLIED WARRANTIES OF MERCHANTABILITY OR FITNESS FOR A PARTICULAR PURPOSE. PURCHASER AGREES THAT IN NO EVENT SHALL MANUFACTURER BE LIABLE FOR SPECIAL, INCIDENTAL OR CONSEQUENTIAL DAMAGES, INCLUDING LOST PROFITS OR LOSS OF USE OR OTHER ECONOMIC LOSS. EXCEPT AS EXPRESSLY PROVIDED HEREIN, MANUFACTURER DISCLAIMS ALL OTHER LIABILITY TO PURCHASER OR ANY OTHER PERSON IN CONNECTION WITH THE USE OR PERFORMANCE OF MANUFACTURER'S PRODUCTS, INCLUDING SPECIFICALLY LIABILITY IN TORT.**

VA-1A, VA-1A-XX

Operating Instructions

OI 041032

Features

1. 12/24 Volt Select Switch

On the back of the VA-1A is a select switch to set the "High Volts" and "Discharge" warning features for a 12 or 24 volt system (see Installation Instructions).

2. "High Volts" Warning Light

If the bus voltage rises to 15.3 volts (30.6 volts for a 24-volt system) or higher, a bright red "High Volts" warning light will alert you of this condition. The high volts feature is sensed off the red power lead and will function regardless of installation variations or what position the mode switch is in. If this light is on, an External Warning Line will be pulled low which can be used to activate an External Warning Light.

3. "Discharge" Warning Light

If the bus voltage drops below 12.6 volts, (25.2 volts for a 24-volt system) a bright yellow "Discharge" warning light will alert you of this condition. The discharge warning feature is sensed off the red power lead and will function regardless of installation variations or what position the mode switch is in. If this light is on, an External Warning Line will be pulled low which can be used to activate an External Warning Light.

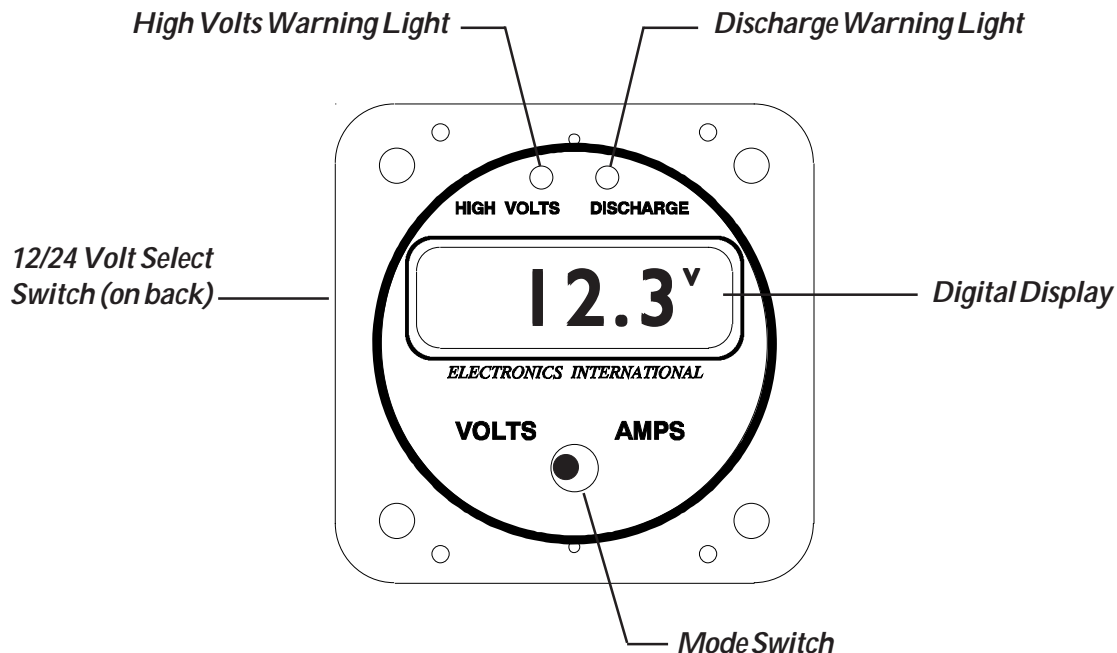

4. Digital Display

The VA-1A comes with 12 and 24 volt digital display back light control lines. The digital display should be backlit all the time. This will allow it to be viewed easily in dim light. The digital display is best viewed in high ambient light or direct sunlight.

Voltage will be displayed in 0.1 volt increments and a "V" annunciator will show in the display. Amperage will be displayed in 0.1 amp increments for the VA-1A and any external shunted unit 60 amps and below (i.e., VA-1A-60 and below). For any external shunted unit above 60 amps (VA-1A-70 and above) amperage will be displayed in 1 amp increments. Any time the Mode Switch is in the "Amps" position, an "A" annunciator will show in the display.

Note: When the VA-1A (-XX) is mounted in the alternator lead and the engine is off, the VA-1A (-XX) may display up to +/- 0.3 amps. This is due to any leakage current in the alternator and any offset in the VA-1A (-XX).

5. Mode Switch

The Mode Switch sets the display between "Volts" and "Amps." The setting of this switch will not affect the operation of the "High Volts" or "Discharge" warning lights.

VA-1A Installed in the Battery Lead

The two common methods of installing the VA-1A or VA-1A-XX in the electrical system of your aircraft are in the battery lead and in the alternator lead. Following are the operating characteristics of the VA-1A installed in the battery lead.

1. Master On, Engine Off

The following describes the operating characteristics of the VA-1A installed in the battery lead with the master switch on and the engine off.

With the Mode Switch in the "Amps" position, the VA-1A will display the electrical system load on the aircraft. Since the engine is off, all of the current is being supplied by the battery. The VA-1A will show a discharging condition (the "Discharge" light will be on) and display an accurate reading of the total current drain from the battery. With all your electrical equipment off, this will be around 2 to 6 amps. In this mode of operation any piece of electrical equipment can be checked for proper operation by performing the following steps:

- A. Note the amps reading on the VA unit.
- B. Turn on the piece of electrical equipment you wish to check.

C. If this piece of electrical equipment is working properly, you will see an increase in load current that corresponds to the current that piece of equipment requires. Compare this current with the current you measured for that same piece of equipment at an earlier date.

Using this method with the digital display of the VA-1A, many important aircraft functions (strobes, retracts, radios, transponder, ADFs, DMEs, pitot heat, etc.) can be checked from the pilot's seat. It would be worthwhile to write down the load current for the entire system and for each piece of equipment. This would give you something to compare to when you wish to check for proper operation at a later date. You may also check the entire electrical system with one check by turning all the electrical equipment on and comparing the amps reading with your normal reading taken at an earlier date. If an improper reading is noted, the VA-1A may then be used to diagnose which piece of equipment has malfunctioned by checking each piece of equipment separately.

With the mode select switch in the "Volts" position, the VA-1A will display the bus voltage to 0.1 volts. With all electrical equipment off and a fully charged battery the bus voltage will be around 12.1 to 12.5 volts (double these levels for a 24-volt system). Each battery has its own operating voltage when charged. As the battery gets near the end of its life, this voltage will start to drop. A discharged battery will also run at a lower voltage. Don't confuse a good discharged battery with an old battery.

2. Master On, Engine On

The following describes the operating characteristics of the VA-1A installed in the battery lead with the master switch on and the engine on.

With the Mode Switch in the "Amps" position, the VA-1A will display the charging current to the battery. When the engine is first started, the current will jump up to 20 amps or more and will quickly decrease as the battery takes a charge. Within a few minutes, the charging current will have dropped to 6 amps or lower and will continue to drop for the next hour until it settles to 1.0 amps or lower.

With the VA-1A installed in the battery lead, load current cannot be monitored during flight. The Alternator (or generator) is supplying all of the electrical load and charging the battery. Only the battery charging current can be monitored for this installation.

With the mode selector switch in the "Volts" position the VA-1A will display the bus voltage to 0.1 volts. With the engine running the alternator is capable of raising the bus voltage to a dangerously high level. It is the voltage regulator's job to limit the bus voltage between 13.5 and 14.8 volts (double these levels for a 24-volt system). Look for this level on the VA-1A. A low voltage reading will cause the battery to charge very slowly. A high reading can damage the battery and most of your electrical equipment. If the aircraft bus voltage goes to a dangerously high level (15.3 volts or higher) a bright red "High Volts" light on the VA-1A will warn you of this condition. If this happens turn the field to the alternator off to eliminate the over voltage condition.

Another common electrical problem is a discharging condition. If this condition goes unnoticed (which it normally does) you will end up with a dead battery in flight rendering all of your electrical equipment useless. To help you avoid this situation the VA-1A has a "Discharge" Warning Light which acts as an early warning, alerting you as soon as the battery goes into a discharging condition. The amount of discharging current can be displayed in the "Amps" position. Discharging current will be displayed as a minus number. If this situation occurs, turn off any unnecessary electrical equipment. The lower you can get the discharging current, the longer the battery will last.

The VA-1A will display trend information when your battery is in a discharging condition. As you watch the battery discharging 0.1 volts at a time, it becomes relatively easy to judge the remaining time you have before the battery reaches a seriously low condition. As the battery voltage approaches 11 volts (22 volts for a 24 volt system), the aircraft's electrical equipment will start to malfunction. The exact voltage at which each piece of equipment will start to malfunction depends on the design of that equipment. The VA-1A will work accurately from 40 to 7 volts--far below where most electrical equipment starts to fail.

VA-1A Installed in the Alternator Lead

Two common methods of installing the VA-1A or VA-1A-XX in the electrical system of your aircraft are in the battery lead and in the alternator lead. Following are the operating characteristics of the VA-1A installed in the alternator lead.

1. Master On, Engine Off

The following describes the operating characteristics of the VA-1A installed in the alternator lead with the master switch on and the engine off.

With the Mode Switch in the "Amps" position the VA-1A will display 000 (+/- a few counts). Since the battery is supplying all of the electrical load and the alternator is off (not turning), there is no current being supplied from the alternator and the "Discharge" warning light will be on.

With the mode select switch in the "Volts" position, the VA-1A will display the bus voltage to 0.1 volts. With all electrical equipment off and a fully charged battery the bus voltage will be around 12.1 to 12.5 volts (double these levels for a 24-volt system). Each battery has its own operating voltage when charged. As the battery gets near the end of its life, this voltage will start to drop. A discharged battery will also run at a lower voltage. Don't confuse a good discharged battery with an old battery.

2. Master On, Engine On

The following describes the operating characteristics of the VA-1A installed in the alternator lead with the master switch on and the engine on.

With the Mode Switch in the "Amps" position the VA-1A will display the electrical system load on the aircraft plus the battery charging current. Since the engine is on, all of the current is being supplied by the alternator. The VA-1A will show a charging condition (the "Discharge" light will be off) and display an accurate reading of the total current drain from the alternator. In this mode of operation any piece of electrical equipment can be checked for proper operation during flight by performing the following steps:

- A. Note the amps reading on the VA unit.
- B. Turn off the piece of electrical equipment you wish to check.
- C. If this piece of electrical equipment is working properly, you will see a decrease in load current that corresponds to the current that piece of equipment requires. Compare this current with the current you measured for that same piece of equipment at an earlier date.

Using this method with the digital display of the VA-1A, many important aircraft functions (strobes, retracts, radios, transponder, ADFs, DMEs, pitot heat, etc.) can be checked from the pilot's seat. It would be worthwhile to write down the load current for the entire system and for each piece of equipment. This would give you something to compare to when you wish to check for proper operation at a later date. You may also check the entire electrical system with one check by turning all the electrical equipment on and comparing this reading with your normal reading taken at an earlier date. If an improper reading is noted, the VA-1A may then be used to diagnose which piece of equipment has malfunctioned by checking each piece of equipment separately.

With the mode selector switch in the "Volts" position the VA-1A will display the bus voltage to .1 volts. With the engine running the alternator is capable of raising the bus voltage to a dangerously high level. It is the voltage regulator's job to limit the bus voltage between 13.5 and 14.8 volts (double these levels for a 24-volt system). Look for this level on the VA-1A. A low voltage reading will cause the battery to charge very slowly. A high reading can damage the battery and most of your electrical equipment. If the aircraft bus voltage goes to a dangerously high level (15.3 volts or higher) a bright red "High Volts" light on the VA-1A will warn you of this condition. If this happens turn the field to the alternator off to eliminate the over voltage condition.

Another common electrical problem is a discharging condition. If this condition goes unnoticed (which it normally does) you will end up with a dead battery in flight rendering all of your electrical equipment useless. To help you avoid this situation the VA-1A has a "Discharge" Warning Light which acts as an early warning to alert you as soon as the battery goes into a discharging condition. If this situation occurs, turn off any unnecessary electrical equipment. The lower you can get the discharging current, the longer the battery will last. With the VA-1A installed in the alternator lead, discharging current cannot be monitored.

The VA-1A will display trend information when your battery is in a discharging condition. As you watch the battery discharging .1 volts at a time, it becomes relatively easy to judge the remaining time you have before the battery reaches a seriously low condition. As the battery voltage approaches 11 volts (22 volts for a 24-volt system), the aircraft's electrical equipment will start to malfunction. The exact voltage at which each piece of equipment will start to malfunction depends on the design of that equipment. The VA-1A will work accurately from 40 to 7 volts--far below where most electrical equipment starts to fail.

VA-1A, VA-1A-XX

Installation Instructions

II 040934

General Information

There are two types of volt/amp meters used in aircraft: Internal Shunt Units and External Shunt Units.

1. Internal Shunt Units

Electronics International Inc. manufactures a VA-1A which is our only internal shunt unit. It has the shunt built into the unit, has two large lugs on the back of the unit and all of the electrical current passes through this gauge. Use this gauge if your aircraft is currently wired for an internal shunt unit or if you elect to route your main alternator or battery supply line up to the instrument panel. As with all internal shunt units, the current capability is limited. The VA-1A is capable of handling 100 amps continuous current. If your aircraft's electrical system is designed to draw more than 100 amps continuous current, you should use one of our external shunt units.

2. External Shunt Units

An external shunt is a strip of metal, usually mounted on a bakelite base. This metal is made of special alloys to produce a very small, precise signal when current passes through it and is not affected by temperature changes.

If your aircraft currently has an external shunt you should order a gauge to match that shunt. Electronics International manufactures a line of external shunt units (VA-1A-XX, "XX" = shunt value in amps) that will match any shunt on the market. If your aircraft does not have an external shunt and you elect to install an external shunt, then order the VA-1A-50 and S-50 shunt (100 amp capability). For aircraft drawing more than 100 amps order the VA-1A-300 and an S-300 shunt (300 amp capability). Please note: The VA-1A and VA-1A-50 resolve to .1 amp and all other units resolve to 1 amp. With our digital display, one amp resolution will still make an excellent electrical diagnostic tool since the current requirements for almost all pieces of equipment in an aircraft are more than one amp.

Installation

1. Important Information and Initial Check Out

- A. **The installer and aircraft owner must read the Warranty before starting the installation.** There is information in the Warranty that may alter your decision to install this instrument. **If you do not accept the terms of the Warranty, do not install this instrument.**
- B. **If you are not an FAA Certified Aircraft Mechanic familiar with the issues of installing aircraft VA instruments, Do Not attempt to install this instrument.** The installer should use current aircraft standards and practices to install this instrument (refer to AC 43.13).

Installation Instructions

1. Important Information and Initial Check Out

- D. Read the entire Installation Instructions and resolve any issues you may have before starting the installation. This may eliminate any delays once the installation is started.
- E. Check that the instrument make and model marked on the side of the instrument and on the invoice are correct before starting the installation. The S-50 Shunt is marked "100MV" and "100 AMP". The S-300 Shunt is marked "50MV" and "300 AMP."
- F. Before starting the installation make sure the unit will fit in the location you intend to install it without obstructing the operation of any controls.
- G. If this instrument is to replace an existing unit in the aircraft, it is the installer's responsibility to move or replace any existing instruments or components in accordance with FAA approved methods and procedures.

2. Instrument Set Up

On the back of the VA-1A is a hole allowing access to a small switch. The switch furthest to the right in this window sets the VA-1A for a 12 or 24 volt system. The other switches have no effect on the operation of the VA-1A. If you have a 12-volt system set this switch down. If you have a 24-volt system set this switch up.

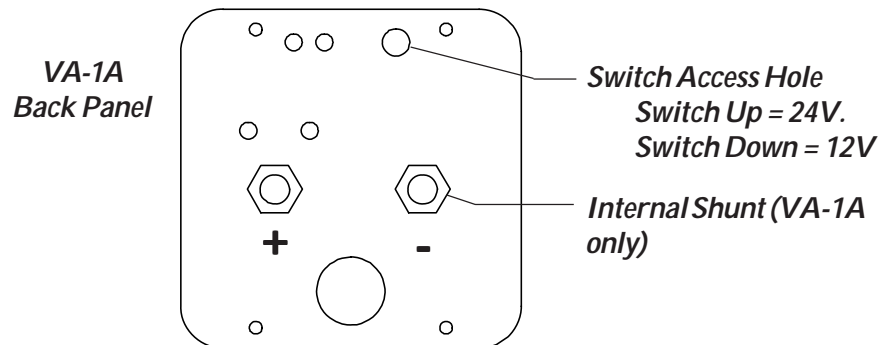

3. Determine how the VA Unit will be installed in your aircraft's electrical system

Obtain an electrical diagram of your aircraft's alternator/starter system from the service manual. There are two common ways an ammeter is installed in an aircraft. One method is with the ammeter in the generator or alternator lead. The other method is with the ammeter in the battery lead. The VA-1A or VA-1A-XX may be installed using either method. The advantages and disadvantages of each method are listed below.

Installation Method	Advantages	Disadvantages
Battery Lead:	<ol style="list-style-type: none"> 1. Shows load current on the ground (engine off) and during an alternator failure. 2. All Warning Lights are operational. 	<ol style="list-style-type: none"> 1. Cannot show load current during flight or when the engine is running.
Alternator Lead:	<ol style="list-style-type: none"> 1. Shows load current during flight or when the engine is running. 2. All Warning Lights are operational. 	<ol style="list-style-type: none"> 1. Cannot show load current when the engine is off or during an alternator failure.

With the improvements made to the VA-1A there are few disadvantages using either method. Although EI's test pilot has a slight preference for the alternator lead when using the VA-1A, ease of installation should be the determining factor. In most cases installing the VA-1A is a simple matter of replacing your existing unit and adding a few wires (see Wiring Diagram).

Following is a typical diagram of each installation. Determine how the VA-1A or External Shunt will be installed in your aircraft.

Figure 1: VA-1A or External Shunt Installed in the Battery Lead

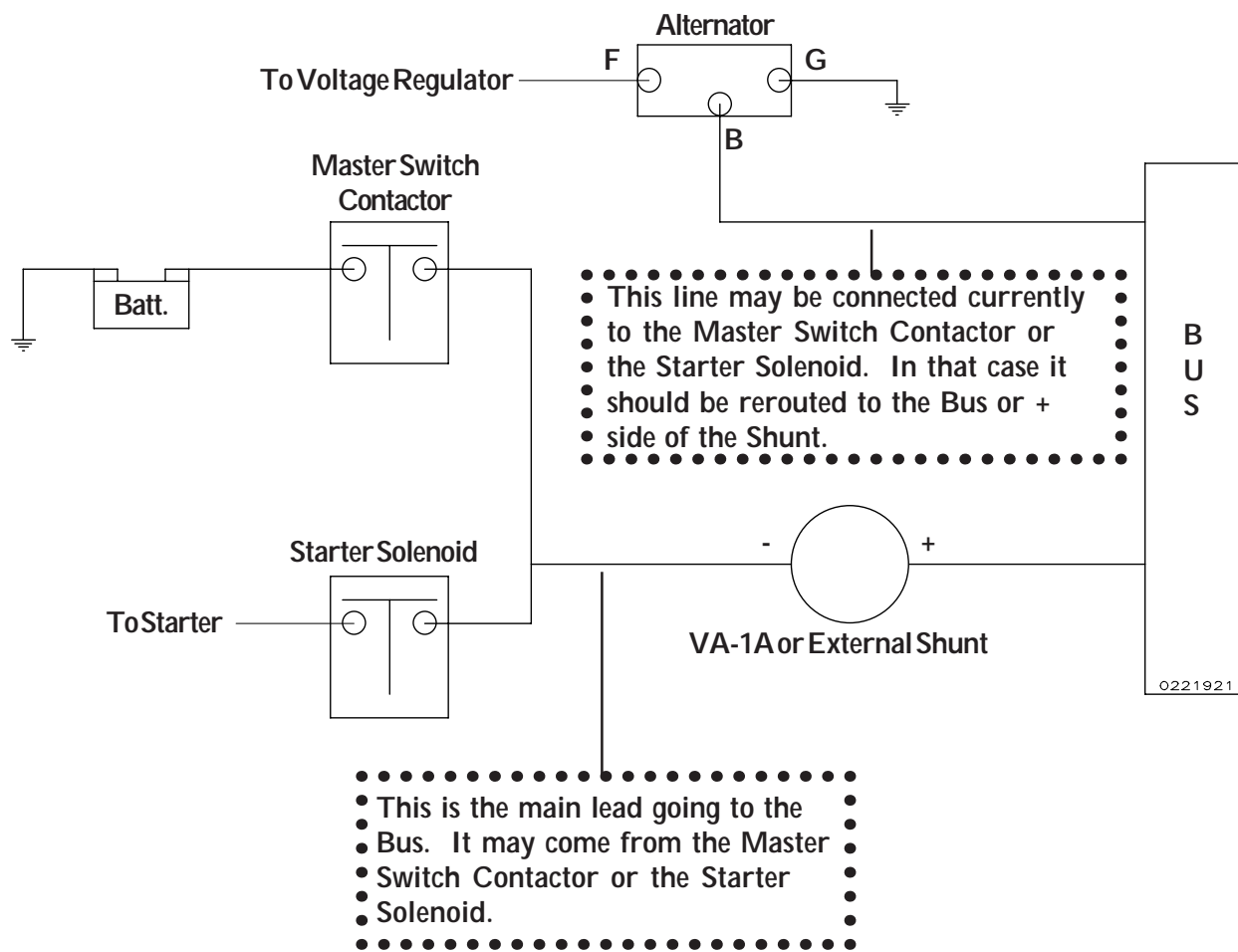

Note: The VA-1A or External Shunt should not be installed in series with the starting current.

Figure 2: VA-1A or External Shunt Installed in the Alternator Lead

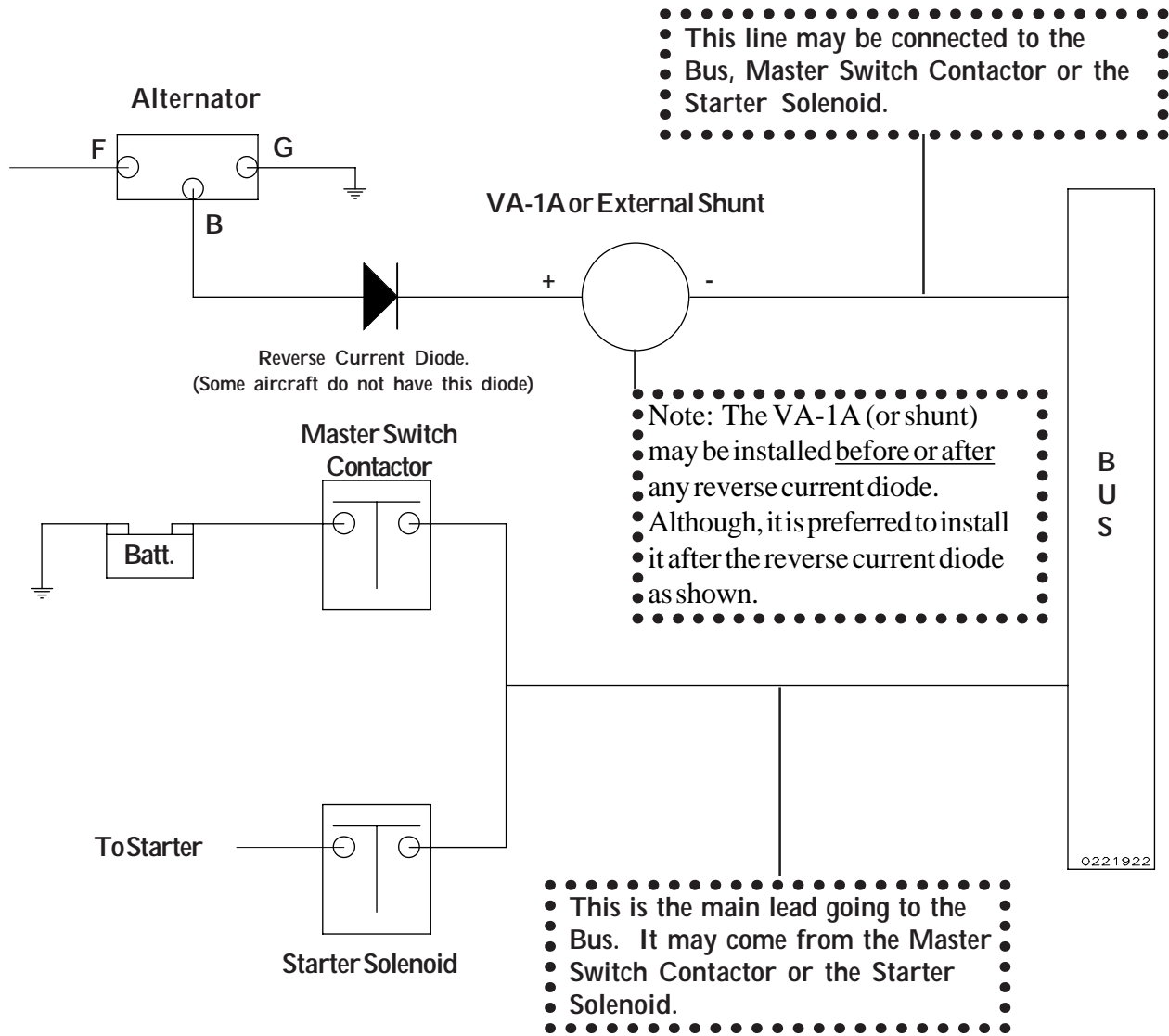

4. Install the External Shunt (External Shunt Unit Only, VA-1A-XX)

Note: If you are replacing an existing ammeter, the shunt may already be mounted in the aircraft. If this is the case, you should have ordered a VA-1A-XX unit that matches your shunt.

The external shunt should be installed in an appropriate location that minimizes the routing of main cables (refer to the wiring diagram in this manual appropriate for your installation). It should also be mounted in a location where inadvertent damage cannot occur. If the shunt can be accessed easily, it should be covered. When mounting the shunt, use self-locking or safety wired nuts.

In some rare instances a shunt may be mounted in the negative battery lead to ground. The VA-1-XX may be connected to this shunt and will work properly.

5. Route the Circular Connector

Starting from under the instrument panel, route the circular connector end of the wire harness up to the instrument mounting location. (See the wiring diagram at the back of this section). Place the circular connector about 8 inches back from the panel. Tie wrap the harness in place approximately 1 foot back from the circular connector. This will allow the harness to be flexible and accommodate varying lengths in instrument wires. **Be sure these wires do not obstruct the freedom of travel of any controls.**

6. Route the Power and Ground Wires

Route the red wire in the wire harness to the aircraft's 12 or 24 volt main or emergency bus as applicable via an independent circuit breaker (one to two amps). An alternate method would be to route the red lead to the bus via a one amp in-line fuse. With this method a spare fuse should be kept in the aircraft. See the Wiring Diagram at the back of this manual.

Route the black wire in the wire harness to a good ground . **Tie wrap these wires so they do not obstruct the freedom of travel of any controls.**

7. Route the Backlight Wires

For a 12 Volt system connect the White/Brown to the 12 Volt bus. Connect the White/Red wire to ground.

For a 24 Volt system connect the White/Red wire to the 24 Volt bus. Leave the White/Brown wire open.

8. Route the Shunt Wires (External Shunt Unit Only, VA-1A-XX)

Route the orange wire to the "+" side of the shunt via a one amp fuse. See the appropriate wiring diagram in this manual for your installation. Connect the brown wire to the "-" side of the shunt via a one amp fuse. If you are replacing an existing unit, most of the wires and all of the fuses should already be in place.

If this unit is to be used with an RSVA-3 remote switch, see the RSVA-3 Installation section of this manual.

9. Connect the Large Shunt Wires (Internal Shunt Unit Only, VA-1A)

Connect the large bus, battery or alternator leads (as appropriate for your installation) to the large lugs on the back of the VA-1 unit. If any major current carrying wire is extended you must use the same size wire as the original. See the appropriate wiring diagram in this manual for your installation.

10. Route the (Optional) External Warning Control Line

The white/yellow wire can be connected to an external light (AL-1), buzzer (ATG-1), a relay, etc. This wire grounds when the Discharge High Volts Warning Light is on. The current in this line must be limited to 2/10 of an amp maximum. Exceeding this limit will damage the unit. If this feature is not used, leave this line open. **Tie wrap this wire so it does not obstruct the freedom of travel of any controls.**

11. Install the Instrument in the Panel

Install the instrument from behind the instrument panel using 6 x 32 screws. These screws should not be any longer than 1/2".

12. Connect the Circular Connector to the Instrument

- 1) Push the two mating connectors together and twist them until they snap into position.
- 2) Turn the locking ring on the instrument connector clockwise (1 1/2 turns) until it locks into position.

13. Ground Test

VA-1A Installed in the Battery Lead - With the master on and the engine off, the discharge light should be on, the Volts position will read 11.9 to 12.5 volts (23.8 to 25 volts for a 24 volt system) and the Amps position should read -2.0 to -10.0 amps depending on your current load for the aircraft. Changing the load will change the amps reading.

With the master on and the engine on, all lights will be off, the Volts position will read 13.2 to 14.8 volts (26.4 to 29.6 for a 24 volt system) and the Amps position will read 5.0 to 15.0 amps and reducing rapidly (shows battery charging current). Changing the load will not change the amps reading. See the operating section of this manual for further details.

VA-1A Installed in the Alternator Lead - With the master on and the engine off, the discharging light will be on, the Volts position will read 11.9 to 12.5 volts (23.8 to 25 volts for a 24 volt system) and the Amps position should read 0.0 amps +/- 0.2 amps. Changing the load will not change the amps reading.

With the master on and the engine on, all lights will be off, the Volts position will read 13.2 to 14.8 volts (26.4 to 29.6 for a 24 volt system) and the Amps position will read 5.0 to 25.0 amps and reducing rapidly (shows battery charging current plus load current for the aircraft). Changing the load will change the amps reading. See the operating section of this manual for further details.

Troubleshooting

If your VA-1A or VA-1A-XX has a problem, perform the following troubleshooting suggestions in the order listed below:

1. Volts Read Incorrectly

Connect only the red and black lead (all other leads must be open). The unit must read correct voltage on the Red lead. Check for poor connections on the red and black lead. You may have a problem with the unit.

2. Amps Read Incorrectly

A. Check that the red and black leads have good connections.

B. For a VA-1A (internal shunt unit), connect only one of the shunt leads on the back of the unit to the bus. (The other lead should be open). The unit must read 00.0 (+/-0.3) Amps.

Troubleshooting

- C. For a VA-1A-XX (external shunt unit), connect both shunt leads (orange and brown) to the bus or one side of the shunt. The unit must read 00.0 (+/- 0.3) Amps. A poor connection in the orange or brown lead will cause only the Amps reading to wander around. Check for poor connections (pull on each wire at the back of its connector). Check the fuses and fuse holders. Check that the signal shunt leads do not supply power to any other piece of equipment.

3. Discharge Warning Light Works Incorrectly

Check that the 12/24 Volt Select Switch on the back of the unit is set properly. The Discharge Warning Light will be on when the bus voltage (on the Red wire) drops below 12.6 volts (25.2 volts for a 24-volt system).

4. High Volts Warning Light Works Incorrectly

Check that the 12/24 Volt Select Switch on the back of the unit is set properly. The High Volts Warning Light will be on when the bus voltage (on the Red wire) exceeds 15.3 volts (30.6 volts for a 24-volt system).

5. Back Light Works Incorrectly

On a 12-volt system, the 24 volt line must be grounded. See the Wiring Diagram. Check for poor connection on the backlight wires (white/brown and white/red).

6. Bench Test the Instrument

To bench test the VA-1A or the VA-1A-XX connect one lead of the internal shunt (or both the orange and brown leads for the VA-1A-XX) to the red lead and connect all of them to a power supply (7 to 40 volts). Connect the black lead to ground. The unit must read 00.0 (+/- 0.3) Amps and proper voltage.

VA-1A (Internal Shunt Unit) Wiring Diagram

W0225921

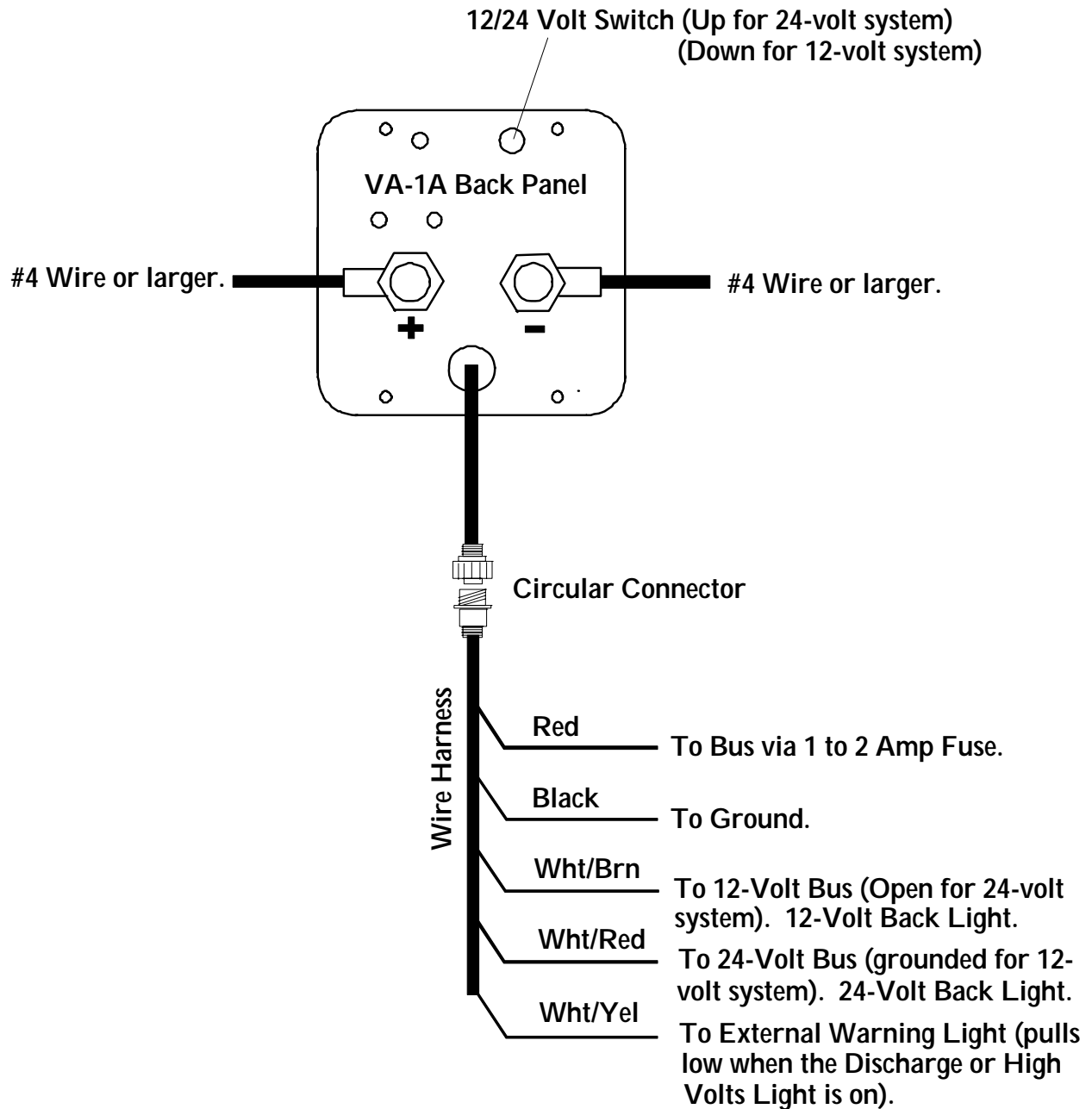

VA-1A-XX (External Shunt Unit) Wiring Diagram

W0225922

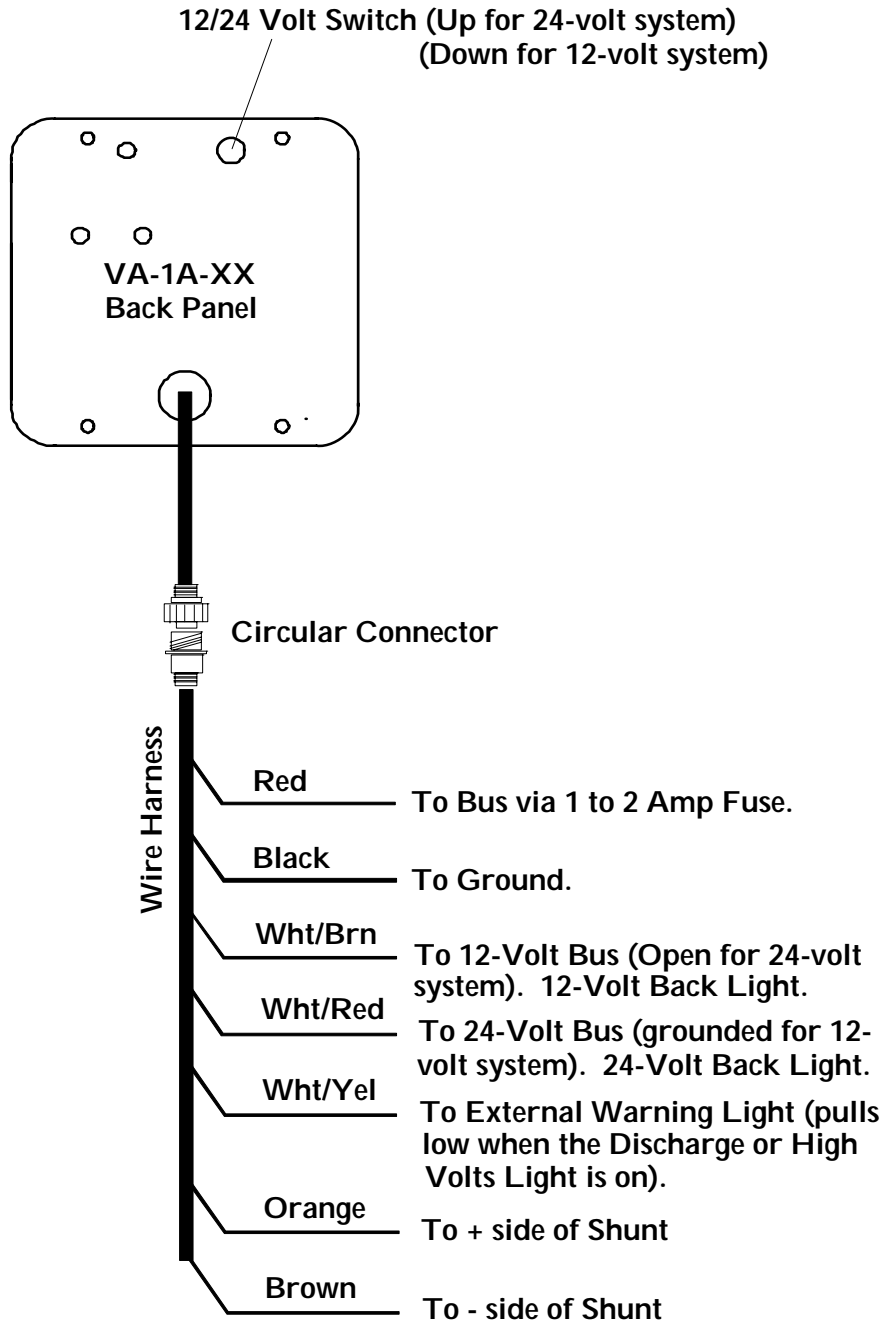

VA-1A and VA-1A-XX

Circular Connector

Wire Harness Connector, Back View (wire side)

OR

Instrument Connector, Front View

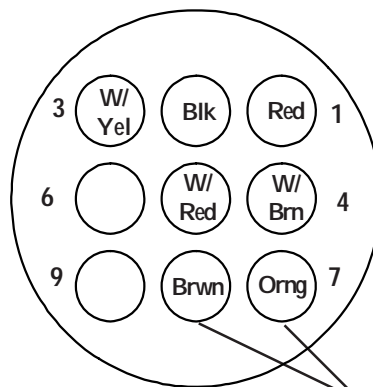

Note: See Wiring Diagram for hook up information.

VA-1A-XX External Shunt Unit Only.

RSVA-3

Installation Instructions

The RSVA-3 switch is used in conjunction with a VA-1A-XX external shunt unit in a twin engine aircraft to monitor both alternator outputs and the battery charging and discharging currents.

1. Install the External Shunts

Note: If you are replacing an existing ammeter, the shunts may already be mounted in the aircraft. If this is the case, you should have ordered a VA-1A-XX unit that matches your existing shunts.

The external shunts should be installed in an appropriate location that minimizes the routing of main cables (refer to the wiring diagram at the end of this section). Also, they should be mounted in a location where inadvertent damage cannot occur. If the shunts can be accessed easily, they should be covered. When mounting the shunts, use self-locking or wired nuts.

2. Install the VA-1A-XX Instrument

Install the VA-1A-XX in the aircraft as described in the VA-1A, VA-1A-XX Installation Instruction section of this manual.

3. Route the Shunt Wires

Route the wires from the + and - terminals of each shunt to the RSVA-3 switch mounting location via a one amp fuses (see the RSVA-3 Wiring Diagram at the back of this section). Pair the wires for each shunt with the corresponding wires in the RSVA-3 harness and crimp a female connector onto the wires connecting to the "+" terminal of each shunt and a male connector onto the wires connecting to the "-" terminal of each shunt, and a male connector on "+" wire of the harness (solid color) and a female connector on the "-" wire of the harness (white with stripe). Red slip-on connectors are provided in the RSVA-3 kit. When preparing the wires to be crimped, strip each wire and double the wires over. Doubling the wires over and a good tight crimp are critical for a good reliable connections. Connect the shunt wires to the RSVA-3 harness.

4. Route the Instrument Wires to the RSVA-3

Route the brown and orange wires in the VA-1A-XX instrument wire harness to the RSVA-3 switch mounting location. Crimp a female connector on the brown wire from the VA-1A-XX and a male connector on the brown wire in the RSVA-3 harness, and a male connector on the orange wire from the VA-1A-XX and a male connector on the orange wire in the RSVA-3 harness. Red slip-on connectors are provided in the RSVA-3 kit. When preparing the wires to be crimped, strip

each wire and double the wires over. Doubling the wires over and a good tight crimp are critical for a good reliable connections.

Connect the VA-1A-XX instrument wires to the RSVA-3 harness wires.

5. Install the RSVA-3 in the Panel

The RSVA-3 requires a 1" x 1" square mounting hole. Install the RSVA-3 switch from behind the instrument panel using the screws and nuts provided in the RSVA-3 kit. Push the two mating connectors of the RSVA-3 and its harness together and twist until they snap into position. Turn the locking ring on the RSVA-3 connector clockwise (1 1/2 turns) until it locks into position. Tie wrap the harness making sure these wires do not obstruct the freedom of travel of any controls.

6. Ground Test

RSVA-3 in the Battery Position - With the master on and the engine off, the discharge light on the VA-1A-XX should be on, the Volts position will read 11.9 to 12.5 volts (23.8 to 25 volts for a 24 volt system) and the Amps position should read -2.0 to -10.0 amps depending on your current load for the aircraft. Changing the load will change the amps reading.

With the master on and the engine on, all lights on the VA-1A-XX will be off, the Volts position will read 13.2 to 14.8 volts (26.4 to 29.6 for a 24 volt system) and the Amps position will read 5.0 to 15.0 amps and reducing rapidly (shows batter changing current). Changing the load will not change the amps reading. See the operating section of this manual for futher details.

RSVA-3 in the Left or Right Alternator Position - With the master on and the engine off, the discharging light on the VA-1A-XX instrument will be on, the Volts position will read 11.9 to 12.5 volts (23.8 to 25 volts for a 24 volt system) and the Amps position should read 0.0 amps +/- 0.3 amps. Changing the load will not change the amps reading.

With the master on and the engine on, all lights on the VA-1A-XX will be off, the Volts position will read 13.2 to 14.8 volts (26.4 to 29.6 for a 24 volt system) and the Amps position will read 5.0 to 25.0 amps and reducing rapidly (shows battery charging current plus load current for the aircraft). Changing the load will change the amps reading. See the operating section of this manual for futher details.

Figure 3: VA-1A-XX and RSVA-3 Installed in a Twin Engine Aircraft

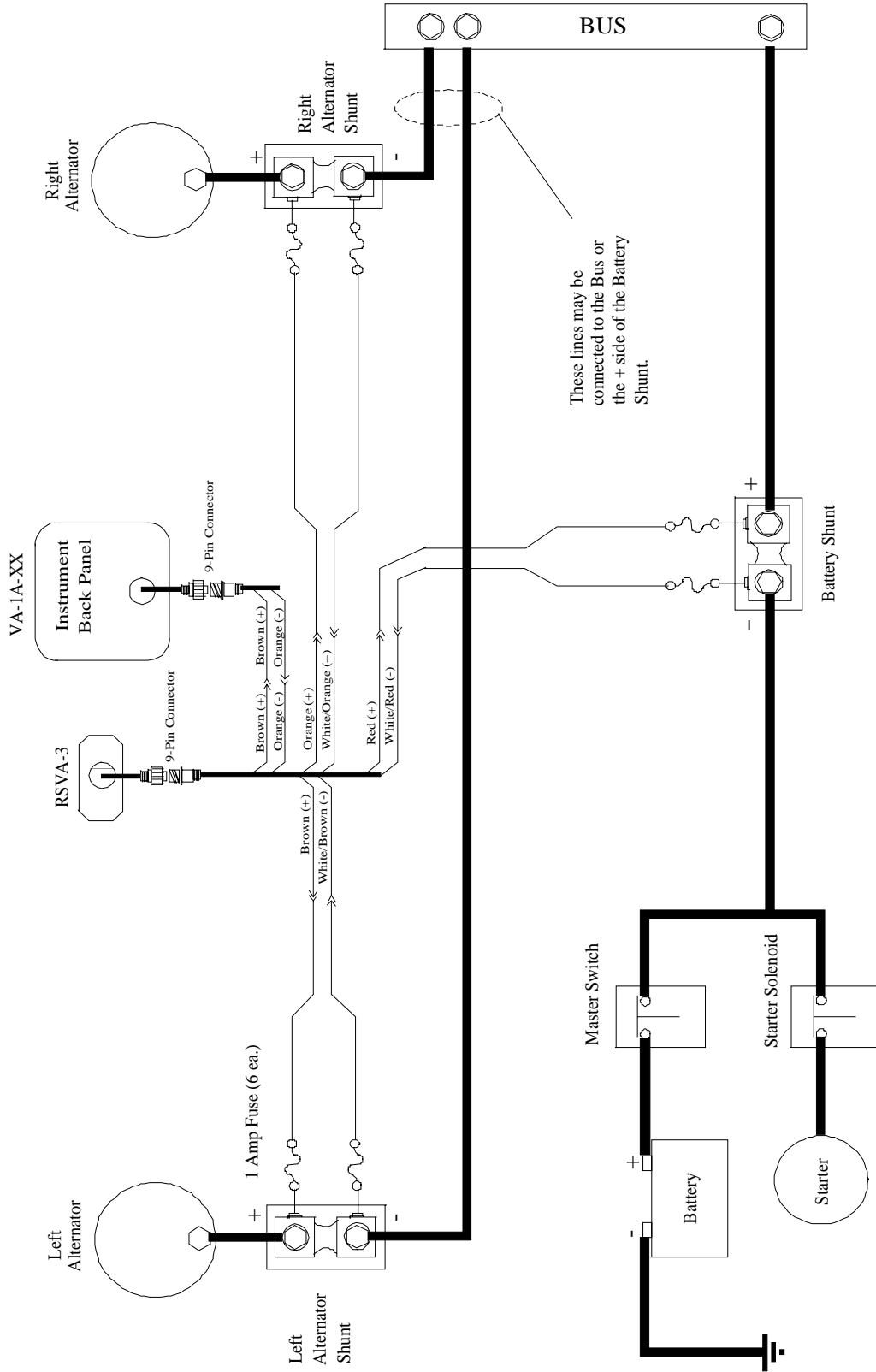

RSVA-3

Circular Connector

Wire Harness Connector, Back View (wire side)

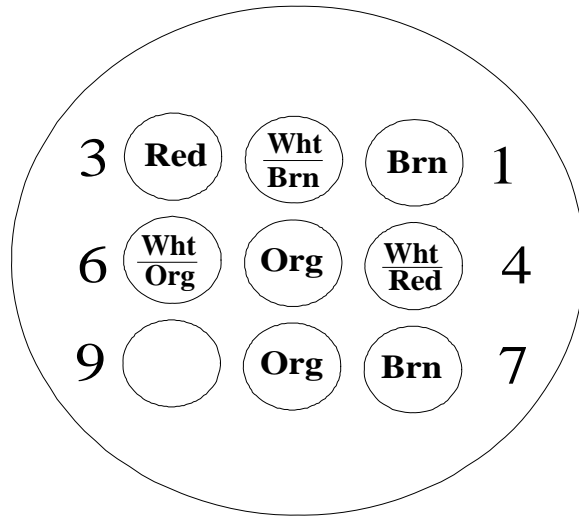

Note: See Wiring Diagram for hook up information.

Specifications and Operating Features

S0224921

Model: VA-1A and VA-1A-XX

Weight: VA-1A ; 9 oz., VA-1A-XX ; 7.5 oz., S-50 (100 amp Shunt) ; 3 oz., S-300 (300 amp Shunt) ; 12 oz., RSVA-3 (External Select Switch) ; 3.5 oz.

Power Requirements: 7 to 40 volts, 2/10 AMP.

Display: 0.35" high resolution LCD display (viewable in direct sunlight). 12 and 24-volt backlight wires are provided for night operation.

Resolution: VA-1A and VA-1A-XX (60 amps and below) resolve amperage to 0.1 amps. VA-1A-XX (above 60 amps) resolves amperage to 1 amps. All units resolve voltage to 0.1 volts.

Accuracy: 1% of reading plus or minus one count (Amps and Volts).

Discharge Warning Light: For a 12-volt system, the light will be on for bus voltages below 12.8 volts (+/- 0.2 volts). For a 24-volt system, the light will be on for bus voltages below 25.6 volts (+/- 0.4 volts). The signal is sensed off the red lead.

High Volts Light: For a 12-volt system, the light will be on for bus voltages above 15.4 volts (+/- 0.3 volts). For a 24-volt system, the light will be on for bus voltages above 30.8 volts (+/- 0.6 volts). The signal is sensed off the red lead.

12/24 Volt Select Switch: A select switch is available on the back of the unit to configure the unit for a 12 or 24-volt electrical system.

VA-1A Configuration: Contains an internal shunt for measuring currents to 100 amps and voltages to 40 volts.

VA-1A-XX Configuration: This unit must be matched to the aircraft's external shunt (i.e., 100 amp, 50 mV external shunt must use a VA-1A-100).

Supplemental Type Certificate

Number SA2693NM

This certificate, issued to

Electronics International, Inc.
63296 Powell Butte Highway
Bend, OR 97701

certifies that the change in the type design for the following product with the limitations and conditions therefor as specified hereon meets the airworthiness requirements of Part * of the Civil Air Regulations.

Original Product—Type Certificate Number: * See attached Master Eligibility List (MEL)
Make: * No. SA2693NM for list of approved airplane
Model: * models and applicable regulations

Description of the Type Design Change: Installation of Electronics International Digital Volt/Amp Gauges and Accessories in accordance with Electronics International, Inc. Installation Instructions No. II 040934.

<u>*Model</u>	<u>Type</u>	<u>Adaptability</u>
VA-1A	Volt/Amp Gauge	Internal Shunt
VA-1A-50	Volt/Amp/Gauge	Connected to Aircraft External Shunt
through		
VA-1A-500		
RSVA-3	Switch (Remote)	For Twin Engine Only Adapted to Aircraft External Shunt
S-50	External Shunt 50-500 Amp	Used with Units Requiring External Shunts
through		
S-500		

* NOTE: The above models are approved as replacements

Limitations and Conditions: Approval of this change in type design applies to the above referenced aircraft models only. This approval should not be extended to other aircraft of this model on which other previously approved modifications are incorporated unless it is determined that the relationship between this change and any of those other previously approved modifications, including changes in type design, will introduce no adverse effect upon the airworthiness of that aircraft. A copy of this Certificate, MEL SA2693NM, and Electronics International, Inc. Instructions No. II 040934 must be maintained as part of the permanent records for the modified aircraft.

If the holder agrees to permit another person to use this certificate to alter the product, the holder shall give the other person written evidence of that permission.

This certificate and the supporting data which is the basis for approval shall remain in effect until surrendered, suspended, revoked, or a termination date is otherwise established by the Administrator of the Federal Aviation Administration.

Date of application: July 8, 1983
Date of issuance: February 16, 1985

Date reissued: December 29, 2004
Date amended: 1/26/1988; 2/21/2002; 1/24/05



By *[Signature]*
(Signature)

Acting Manager, Seattle Aircraft Certification Office
(Title)

Any alteration of this certificate is punishable by a fine of not exceeding \$1,000, or imprisonment not exceeding 3 years, or both.

This certificate may be transferred in accordance with FAR 21.47.

FAA Approved Model List (AML) SA2693NM

For

Electronics International, Inc. VA-1A Primary Volt/Amp Instruments and Accessories

ITEM	AIRCRAFT MAKE	AIRCRAFT MODEL	ORIGINAL TYPE CERTIFICATE NUMBER	CERTIFICATION BASIS For ALTERATION	FAA APPROVED DRAWINGS		INSTALLATION INSTRUCTIONS		AML AMENDED DATE
					Number	Revision	Number	Revision	
-----	-----	-----	-----	-----	TD 031851	B 01/05/07 or later FAA Approved Revision	II 040934	C 02/24/92 or later FAA Approved Revision	-----
1	Artic Aircraft Co.	S-1A Series	A-737	CAR 4A	"	"	"	"	I.R.
		S-1B Series	A-754	CAR 4A	"	"	"	"	I.R.
2	Ayres Corp	S2R Series	A3SW	CAR 3	"	"	"	"	I.R.
		S2R Series	A3SW	CAR 8	"	"	"	"	I.R.
3	Aerospatiale (Nord-Aviation)	SE.3160, SA.316B, SA.315B, SA.319B, SA.316C	H1 IN	CAR 10	"	"	"	"	8/26/1986
		262A Series	A6EU	CAR 10	"	"	"	"	8/26/1986
		SN-601	A37 EU	FAR 21.29	"	"	"	"	8/26/1986
		SA-350 Series, SA-365 Series	H8 EU	FAR 21.29	"	"	"	"	8/26/1986
		SA-365 Series	H10 EU	FAR 21.29	"	"	"	"	8/26/1986
4	Air Tractor Inc.	AT-250, AT-300, AT-301, AT-302, AT-400, AT-400A	A9SW	FAR 21.25(a)(1)	"	"	"	"	12/10/2009
		AT-401, AT-401A, AT-401B, AT-402, AT-402A	A17SW	FAR 21.25(a)(1)	"	"	"	"	12/10/2009
		AT-402B, AT-501, AT-502, AT-502A, AT-502B	A17SW	FAR 21.25(a)(1)	"	"	"	"	12/10/2009
		AT-503, AT-503A, AT-504	A17SW	FAR 21.25(a)(1)	"	"	"	"	12/10/2009
		AT-602, AT-802, AT-802A	A19SW	FAR 23	"	"	"	"	12/10/2009
5	Allied Ag Cat	G-164 Series	1A16	CAR 8.10(a)(1)	"	"	"	"	12/10/2009
6	Ballauer	Funk Series	2-564	CAR 4	"	"	"	"	I.R.
7	Beech Aircraft Corp	18 Series	A-757	CAR 4A	"	"	"	"	I.R.
		18 Series	A-765	CAR 3	"	"	"	"	I.R.
		19 Series, 23 Series, 24 Series	A1CE	CAR 3	"	"	"	"	I.R.
		33 Series, 35 Series, 36 Series	3A15	CAR 3	"	"	"	"	I.R.
		45 Series	5A3	CAR 3	"	"	"	"	I.R.
		50 Series	5A4	CAR 3	"	"	"	"	I.R.
		60 Series	A12CE	FAR 23	"	"	"	"	I.R.
		65 Series, 90 Series	3A20	CAR 3	"	"	"	"	I.R.
		76 Series	A29CE	FAR 23	"	"	"	"	I.R.
		77 Series	A30CE	FAR 23	"	"	"	"	I.R.
		F90 Series	A31CE	FAR 23	"	"	"	"	I.R.
		95 Series, 55 Series, 56 Series	3A16	CAR 3	"	"	"	"	I.R.
		58 Series	A23CE	FAR 23	"	"	"	"	I.R.
		99 Series, 100 Series	A14CE	FAR 23	"	"	"	"	I.R.
		200 Series	A24CE	FAR 23	"	"	"	"	I.R.
		300 Series, 1900 Series, 1900C Series	A24CE	FAR 23	"	"	"	"	I.R.
8	Bell Helicopter (Textron)	47 Series	H-1	CAR 6	"	"	"	"	8/26/1986
		47 Series	2H3	CAR 6	"	"	"	"	8/26/1986
		47 Series	2H1	CAR 6	"	"	"	"	8/26/1986
		204 Series, 205 Series	H1 SW	CAR 7	"	"	"	"	8/26/1986

FAA Approved Model List (AML) SA2693NM

For

Electronics International, Inc. VA-1A Primary Volt/Amp Instruments and Accessories

ITEM	AIRCRAFT MAKE	AIRCRAFT MODEL	ORIGINAL TYPE CERTIFICATE NUMBER	CERTIFICATION BASIS FOR ALTERATION	FAA APPROVED DRAWINGS		INSTALLATION INSTRUCTIONS		AML AMENDED DATE
					Number	Revision	Number	Revision	
					TD 031851	B 01/05/07 or later FAA Approved Revision	II 040934	C 02/24/92 or later FAA Approved Revision	
		212 Series	H4 SW	FAR 29	"	"	"	"	8/26/1986
		214 Series	H6 SW	FAR 29	"	"	"	"	8/26/1986
		222 Series	H9 SW	FAR 29	"	"	"	"	8/26/1986
		206 Series	H2 SW	CAR 6	"	"	"	"	5/7/1986
9	Bellanca Aircraft Corp	7 Series	A-759	CAR 4A	"	"	"	"	I.R.
		8 Series	A21CE	FAR 23	"	"	"	"	I.R.
		11 Series	A-761	CAR 4A	"	"	"	"	I.R.
		11 Series	A-796	CAR 3	"	"	"	"	I.R.
		14 Series, 17 Series	A-18CE	FAR 23	"	"	"	"	I.R.
		300 Series	ATC328	ATC328	"	"	"	"	I.R.
		400 Series	ATC319	ATC319	"	"	"	"	I.R.
10	British Aerospace	Twin Pioneer Series 2, Twin Pioneer Series 3	7A7	CAR 10	"	"	"	"	I.R.
		Beagle B.206, Series 1, Series 2	A11EU	CAR 3	"	"	"	"	I.R.
		Beagle B.121, Series 1, Series 2, Series 3	A22EU	FAR 23	"	"	"	"	I.R.
11	Cessna Aircraft	120 Series, 140 Series	A-768	CAR 4A	"	"	"	"	I.R.
		140 Series	5A2	CAR 4A	"	"	"	"	I.R.
		150 Series, 152 Series	3A19	CAR 3	"	"	"	"	I.R.
		170 Series	A-799	CAR 3	"	"	"	"	I.R.
		172 Series	3A12	CAR 3	"	"	"	"	I.R.
		172 Series, 175 Series	3A17	CAR 3	"	"	"	"	I.R.
		177 Series	A13CE	FAR 23	"	"	"	"	I.R.
		177 Series	A20CE	FAR 23	"	"	"	"	I.R.
		180 Series	5A6	CAR 3	"	"	"	"	I.R.
		182 Series	3A13	CAR 3	"	"	"	"	I.R.
		185 Series	3A24	CAR 3	"	"	"	"	I.R.
		188 Series	A9CE	FAR 21	"	"	"	"	I.R.
		190 Series	A-790	CAR 3	"	"	"	"	I.R.
		206 Series	A4CE	CAR 3	"	"	"	"	6/6/1990
		207 Series	A16CE	FAR 23	"	"	"	"	I.R.
		210 Series	3A21	CAR 3	"	"	"	"	I.R.
		303 Series	A34CE	FAR 23	"	"	"	"	I.R.
		305 Series	5A5	CAR 3	"	"	"	"	I.R.
		305 Series	3A14	CAR 3	"	"	"	"	I.R.
		310 Series	3A10	CAR 3	"	"	"	"	I.R.
320 Series, 335 Series, 340 Series	3A25	CAR 3	"	"	"	"	I.R.		
336 Series	A2CE	CAR 3	"	"	"	"	I.R.		

FAA Approved Model List (AML) SA2693NM

For

Electronics International, Inc. VA-1A Primary Volt/Amp Instruments and Accessories

ITEM	AIRCRAFT MAKE	AIRCRAFT MODEL	ORIGINAL TYPE CERTIFICATE NUMBER	CERTIFICATION BASIS FOR ALTERATION	FAA APPROVED DRAWINGS		INSTALLATION INSTRUCTIONS		AML AMENDED DATE
					Number	Revision	Number	Revision	
					TD 031851	B 01/05/07 or later FAA Approved Revision	II 040934	C 02/24/92 or later FAA Approved Revision	
		337 Series	A6CE	CAR 3	"	"	"	"	I.R.
		401 Series, 402 Series, 411 Series, 414 Series, 421 Series	A7CE	CAR 3	"	"	"	"	I.R.
		425 Series	A7CE	CAR 3	"	"	"	"	I.R.
		404 Series	A25CE	FAR 23	"	"	"	"	I.R.
12	Christen Industries	S-1 Series, S-2 Series	A8SO	FAR 23	"	"	"	"	I.R.
13	Cirrus Design Corporation	SR20, SR22	A00009CH	FAR 23	"	"	"	"	12/10/2009
14	Consolidated Aeronautics	Colonial C-1, Colonial C-2, Lake LA Series, Lake 250	1A13	CAR 3	"	"	"	"	I.R.
15	Enstrom Helicopter	F Series, 280 Series	H1CE	CAR 6	"	"	"	"	I.R.
16	Extra Flugzeugproduktions	EA-300, EA-300S, EA-300/L, EA-300/200	A67EU	FAR 23	"	"	"	"	12/10/2009
17	Gulfstream American	G Series	1A17	CAR 4B	"	"	"	"	I.R.
		G Series	A12EA	CAR 4B	"	"	"	"	I.R.
		G-164 Series	1A16	CAR 8.10(a)(1)	"	"	"	"	I.R.
		AA Series	A11EA	FAR 23	"	"	"	"	I.R.
		AA Series	A16EA	FAR 23	"	"	"	"	I.R.
		GA Series	A17SO	FAR 23	"	"	"	"	I.R.
18	Gulfstream Aerospace	111 Series	A11SO	FAR 23	"	"	"	"	I.R.
		112 Series, 114 Series	A12SO	FAR 23	"	"	"	"	12/20/1988
19	Helio Aircraft Limited	H-250, H-295, HT-295, H-391, H-391B, H-395, H-395A	1A8	CAR 3	"	"	"	"	11/13/1986
20	Hiller Aviation	UH-12 Series	6H1	CAR 6	"	"	"	"	I.R.
		UH-12 Series	6H2	CAR 6	"	"	"	"	I.R.
		UH-12 Series	4H10	CAR 6	"	"	"	"	I.R.
		UH-12 Series	4H11	CAR 6	"	"	"	"	I.R.
		UH-12 Series	H1WE	CAR 6	"	"	"	"	I.R.
21	Howard Aircraft	DGA-8, UC-70C	612	BUL 7A	"	"	"	"	12/10/2009
		DGA-9, DGA-12, UC-70D, UC-70A	645	BUL 7A	"	"	"	"	12/10/2009
		DGA-11	672	BUL 7A	"	"	"	"	12/10/2009
		DGA-15P, DGA-15J, DGA-15W, UC-70, GH-1, GH-2	A-717	CAR 4A	"	"	"	"	12/10/2009
		GH-3, NH-1, UC-70B	A-717	CAR 4A	"	"	"	"	12/10/2009
		DGA-18, DGA-18K	739	CAR 4A	"	"	"	"	12/10/2009
22	Hughes Helicopter	269 Series, 300 Series	4H12	CAR 6	"	"	"	"	I.R.
23	Hynes	H-2 Series, H-4 Series	2H2	CAR 6	"	"	"	"	I.R.
24	Luscombe	8, 8A, 8B, 8C, 8D, 8E, 8F, T-8F	A-694	CAR 4A	"	"	"	"	12/10/2009
25	Maule Aircraft Corp	M Series	3A23	CAR 3	"	"	"	"	I.R.
26	Mooney Aircraft	M20 Series	2A3	CAR 3	"	"	"	"	I.R.
27	North American Navion	AT-6 Series	A-2-575	CAR 4A	"	"	"	"	I.R.
28	Partenavia Costruzioni	P68 Series	A31EU	FAR 23	"	"	"	"	I.R.

FAA Approved Model List (AML) SA2693NM

For

Electronics International, Inc. VA-1A Primary Volt/Amp Instruments and Accessories

ITEM	AIRCRAFT MAKE	AIRCRAFT MODEL	ORIGINAL TYPE CERTIFICATE NUMBER	CERTIFICATION BASIS For ALTERATION	FAA APPROVED DRAWINGS		INSTALLATION INSTRUCTIONS		AML AMENDED DATE
					Number	Revision	Number	Revision	
					TD 031851	B 01/05/07 or later FAA Approved Revision	II 040934	C 02/24/92 or later FAA Approved Revision	
29	Pilatus Britten-Norman	BN Series	A17EU	FAR 23	"	"	"	"	I.R.
30	Piper Aircraft Corp	PA-12 Series	A-780	CAR 3	"	"	"	"	I.R.
		PA-14 Series	A-797	CAR 3	"	"	"	"	I.R.
		PA-15 Series	A-800	CAR 3	"	"	"	"	I.R.
		PA-16 Series	1A1	CAR 3	"	"	"	"	I.R.
		PA-17 Series	A-805	CAR 3	"	"	"	"	I.R.
		PA-18 Series	1A2	CAR 3	"	"	"	"	I.R.
		PA-18 Series	AR-7	CAR 8.10(b)	"	"	"	"	I.R.
		PA-20 Series	1A4	CAR 3	"	"	"	"	I.R.
		PA-22 Series	1A6	CAR 3	"	"	"	"	I.R.
		PA-23 Series	1A10	CAR 3	"	"	"	"	I.R.
		PA-24 Series	1A15	CAR 3	"	"	"	"	I.R.
		PA-25 Series	2A8	CAR 3	"	"	"	"	I.R.
		PA-25 Series	2A10	CAR 8.10(b)	"	"	"	"	I.R.
		PA-28 Series	2A13	CAR 3	"	"	"	"	I.R.
		PA-30 Series	A1EA	CAR 3	"	"	"	"	I.R.
		PA-31 Series	A8EA	CAR 3	"	"	"	"	I.R.
		PA-32 Series	A3SO	CAR 3	"	"	"	"	I.R.
		PA-34 Series	A7SO	FAR 23	"	"	"	"	12/20/1988
		PA-36 Series	A9SO	FAR 23	"	"	"	"	I.R.
		PA-36 Series	A10SO	FAR 21	"	"	"	"	I.R.
		PA-38 Series	A18SO	FAR 23	"	"	"	"	I.R.
PA-39 Series, PA-40 Series	A1EA	CAR 3	"	"	"	"	I.R.		
PA-44 Series	A19SO	FAR 23	"	"	"	"	I.R.		
PA-60-600, PA-60-601, PA-60-601P	A17WE	FAR 23	"	"	"	"	12/20/1988		
PA-60-602P, PA-60-700P	A17WE	FAR 23	"	"	"	"	12/20/1988		
31	Prop-Jet Inc.	200 Series	3A18	CAR 3	"	"	"	"	I.R.
32	Reims Aviation (Cessna)	150 Series	A13EU	FAR 21.29	"	"	"	"	I.R.
		172 Series	A4EU	CAR 10	"	"	"	"	I.R.
		177 Series	A26EU	FAR 23	"	"	"	"	I.R.
		182 Series	A42EU	CAR 3	"	"	"	"	I.R.
		337 Series	A23EU	FAR 23	"	"	"	"	I.R.
		337 Series	A23EU	FAR 23	"	"	"	"	I.R.
33	Robinson Helicopter	R22 Series	H10WE	FAR 27	"	"	"	"	I.R.
34	Stinson Division	SM Series	ATC16	ATC16	"	"	"	"	I.R.
		SM Series	ATC136	ATC136	"	"	"	"	I.R.

FAA Approved Model List (AML) SA2693NM

For

Electronics International, Inc. VA-1A Primary Volt/Amp Instruments and Accessories

ITEM	AIRCRAFT MAKE	AIRCRAFT MODEL	ORIGINAL TYPE CERTIFICATE NUMBER	CERTIFICATION BASIS For ALTERATION	FAA APPROVED DRAWINGS		INSTALLATION INSTRUCTIONS		AML AMENDED DATE
					Number	Revision	Number	Revision	
-----	-----	-----	-----	-----	TD 031851	B 01/05/07 or later FAA Approved Revision	II 040934	C 02/24/92 or later FAA Approved Revision	-----
		SM Series	ATC48	ATC48	"	"	"	"	I.R.
		SM Series	ATC145	ATC145	"	"	"	"	I.R.
		SM Series	ATC161	ATC161	"	"	"	"	I.R.
		SM Series	ATC194	ATC194	"	"	"	"	I.R.
		SM Series	ATC298	ATC298	"	"	"	"	I.R.
		SR Series	ATC519	ATC519	"	"	"	"	I.R.
		SR Series	ATC530	ATC530	"	"	"	"	I.R.
		SR Series	ATC580	ATC580	"	"	"	"	I.R.
		SR Series	ATC594	ATC594	"	"	"	"	I.R.
		SR Series	ATC608	ATC608	"	"	"	"	I.R.
		SR Series	ATC609	ATC609	"	"	"	"	I.R.
35	Sikorsky Aircraft	H19 Series	HRISO	FAR 21.25	"	"	"	"	8/26/1986
		S-39 Series	ATC-375	FAR 21.25	"	"	"	"	8/26/1986
		S-41-B	2-286	FAR 21.25	"	"	"	"	8/26/1986
		S-43 Series	A-593	Aero Bul-7A	"	"	"	"	8/26/1986
		VS-44-A	752	CAR 4A	"	"	"	"	8/26/1986
		S-51 Series	H-2	CAR 6	"	"	"	"	8/26/1986
		S-52 Series	H-3	CAR 6	"	"	"	"	8/26/1986
		S-55 Series	1H4	CAR 6	"	"	"	"	8/26/1986
		S-58 Series	1H11	CAR 6	"	"	"	"	8/26/1986
		S-61 Series	1H15	CAR 7	"	"	"	"	8/26/1986
		S-62 Series	1H13	CAR 7	"	"	"	"	8/26/1986
		S-64 Series	H1EA	CAR 8	"	"	"	"	8/26/1986
S-76 Series	H1NE	FAR 29	"	"	"	"	8/26/1986		
36	Stol Aircraft Corp.	UC-1	A6EA	CAR 3	"	"	"	"	6/6/1990
		RC-3	A-769	CAR 3	"	"	"	"	6/6/1990
37	Thompson Jimmie (Navion)	A through H Series	A-782	CAR 3	"	"	"	"	I.R.
38	Thrush Aircraft, Inc.	600 S2D, S-2R, S2R Series, S2RHG Series	A4SW	CAR 8	"	"	"	"	12/10/2009
		600 S-2D, S-2R, S2R Series	A3SW	CAR 3	"	"	"	"	12/10/2009
		S2A	2A9	CAR 8.10(a)(1)	"	"	"	"	12/10/2009
		S-2B, S-2C, 600-S2C	2A7	CAR 8.10(a)(1)	"	"	"	"	12/10/2009
39	Varga Aircraft Corp	2150 Series	4A19	CAR 3	"	"	"	"	I.R.
40	Waco Aircraft	A Series	ATC 26	ATC 26	"	"	"	"	I.R.
		A Series	664	664	"	"	"	"	I.R.
		A Series	667	667	"	"	"	"	I.R.
		A Series	598	598	"	"	"	"	I.R.

FAA Approved Model List (AML) SA2693NM

For

Electronics International, Inc. VA-1A Primary Volt/Amp Instruments and Accessories

ITEM	AIRCRAFT MAKE	AIRCRAFT MODEL	ORIGINAL TYPE CERTIFICATE NUMBER	CERTIFICATION BASIS For ALTERATION	FAA APPROVED DRAWINGS		INSTALLATION INSTRUCTIONS		AML AMENDED DATE
					Number	Revision	Number	Revision	
-----	-----	-----	-----	-----	TD 031851	B 01/05/07 or later FAA Approved Revision	II 040934	C 02/24/92 or later FAA Approved Revision	-----
		A Series	714	CAR 7A	"	"	"	"	I.R.
		A Series	ATC 41	ATC 41	"	"	"	"	I.R.
		A Series	ATC 123	ATC 123	"	"	"	"	I.R.
		B & C Series	ATC 168	ATC 168	"	"	"	"	I.R.
		B & C Series	ATC 538	ATC 538	"	"	"	"	I.R.
		B & C Series	ATC 362	ATC 362	"	"	"	"	I.R.
		B & C Series	ATC 240	ATC 240	"	"	"	"	I.R.
		B & C Series	ATC 352	ATC 352	"	"	"	"	I.R.
		B & C Series	ATC 575	ATC 575	"	"	"	"	I.R.
		D & E Series	ATC 639	ATC 639	"	"	"	"	I.R.
		D & E Series	ATC 597	ATC 597	"	"	"	"	I.R.
		D Series	ATC 42	ATC 42	"	"	"	"	I.R.
		E Series	665	665	"	"	"	"	I.R.
		E Series	2-430	2-430	"	"	"	"	I.R.
		G Series	ATC 13	ATC 13	"	"	"	"	I.R.
		G Series	2-363	2-363	"	"	"	"	I.R.
		I Series	ATC 345	ATC 345	"	"	"	"	I.R.
		J Series	2-361	2-361	"	"	"	"	I.R.
		K Series	ATC 313	ATC 313	"	"	"	"	I.R.
		O Series	ATC 468	ATC 468	"	"	"	"	I.R.
		P Series	ATC 464	ATC 464	"	"	"	"	I.R.
		P Series	ATC 491	ATC 491	"	"	"	"	I.R.
		P Series	ATC 453	ATC 453	"	"	"	"	I.R.
		P Series	ATC 502	ATC 502	"	"	"	"	I.R.
		R Series	ATC 466	ATC 466	"	"	"	"	I.R.
		R Series	ATC 311	ATC 311	"	"	"	"	I.R.
		S Series	543	543	"	"	"	"	I.R.
		U Series	ATC 479	ATC 479	"	"	"	"	I.R.
		U Series	ATC 473	ATC 473	"	"	"	"	I.R.
		U Series	ATC 467	ATC 467	"	"	"	"	I.R.
		U Series	ATC 499	ATC 499	"	"	"	"	I.R.
		U Series	ATC 511	ATC 511	"	"	"	"	I.R.
		U Series	ATC 546	ATC 546	"	"	"	"	I.R.
		U Series	ATC 568	ATC 568	"	"	"	"	I.R.
		Y Series, Z Series	626	626	"	"	"	"	I.R.
		Y Series, Z Series	ATC 542	ATC 542	"	"	"	"	I.R.

FAA Approved Model List (AML) SA2693NM

For

Electronics International, Inc. VA-1A Primary Volt/Amp Instruments and Accessories

ITEM	AIRCRAFT MAKE	AIRCRAFT MODEL	ORIGINAL TYPE CERTIFICATE NUMBER	CERTIFICATION BASIS FOR ALTERATION	FAA APPROVED DRAWINGS		INSTALLATION INSTRUCTIONS		AML AMENDED DATE
					Number	Revision	Number	Revision	
---	-----	-----	-----	-----	TD 031851	B 01/05/07 or later FAA Approved Revision	II 040934	C 02/24/92 or later FAA Approved Revision	-----
		Y Series, Z Series	ATC 586	ATC 586	"	"	"	"	I.R.
		Z Series	ATC 627	ATC 627	"	"	"	"	I.R.
41	Weatherly Aviation	201 Series	A10WE	FAR 21.25(a)	"	"	"	"	I.R.
		602 Series	A26WE	FAR 21.25(a)	"	"	"	"	I.R.
42	Univar Aircraft (Erco, Forney, Alon) (Stinson, Mooney)	108 Series	A-767	CAR 3	"	"	"	"	I.R.
		G, F-1, F-1A, E, 415-D, A-2, A2-A, M10	A-787	CAR 3	"	"	"	"	I.R.
		415-C, 415-CD	A-718	CAR 4A	"	"	"	"	I.R.
		108, 108-1, 108-2, 108-3, 108-5	A-767	CAR 3	"	"	"	"	6/6/1990
---	End of List	-----	-----	-----	-----	-----	-----	-----	-----

Amended Date: 5/07/1986, 8/26/1986, 11/13/1986, 12/20/1988, 6/06/1990, 12/10/2009

FAA Approved:

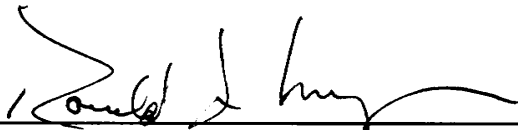

Acting Manager, Seattle Aircraft Certification Office